

EVENT	HCRM	PAGE
\$00	16 0	6,13
\$01	- -	-
\$02	2 1	1,15
\$03	2 4	1,14
\$04	13 9	5,13
\$05	7 13	3,12
\$06	- -	-
\$07	1 4	1,15
\$08	- -	-
\$09	12 8	4,14
\$0A	7 1	3,14
\$0B	5 15	2,12
\$0C	14 12	5,13
\$0D	12 12	4,12
\$0E	16 7	6,13
\$0F	1 5	1,15

EVENT	HCRM	PAGE
\$10	3 12	1,8
\$11	14 1	5,13
\$12	14 2	5,13
\$13	14 3	5,13
\$14	14 4	5,13
\$15	14 5	5,13
\$16	14 6	5,13
\$17	14 7	5,13
\$18	6 10	2,12
\$19	14 8	5,13
\$1A	16 12	6,13
\$1B	14 15	5,13
\$1C	14 9	5,13
\$1D	14 10	5,13
\$1E	5 5	2,13
\$1F	5 6	2,13

EVENT	HCRM	PAGE
\$20	15 0	6,13
\$21	15 1	6,13
\$22	3 11	1,10
\$23	15 2	6,13
\$24	10 6	4,14
\$25	3 14	1,10
\$26	3 15	1,10
\$27	1 10	1,13
\$28	9 5	3,13
\$29	15 9	6,13
\$2A	15 10	6,13
\$2B	15 11	6,13
\$2C	4 15	2,9
\$2D	15 13	6,13
\$2E	15 14	6,13
\$2F	1 11	1,10

EVENT	HCRM	PAGE
\$30	13 3	5,13
\$31	6 8	2,11
\$32	13 8	5,13
\$33	8 1	3,11
\$34	5 7	2,10
\$35	7 14	3,12
\$36	7 15	3,12
\$37	7 12	3,12
\$38	9 13	3
\$39	9 14	3,7
\$3A	10 7	4,11
\$3B	10 13	4,12
\$3C	4 6	2,11
\$3D	3 4	1,11
\$3E	3 3	1,13
\$3F	8 2	3,12

EVENT	HCRM	PAGE
\$40	- -	-
\$41	- -	-
\$42	- -	-
\$43	- -	-
\$44	- -	-
\$45	- -	-
\$46	- -	-
\$47	- -	-
\$48	- -	-
\$49	- -	-
\$4A	- -	-
\$4B	- -	-
\$4C	9 0	3,12
\$4D	- -	-
\$4E	- -	-
\$4F	- -	-

EVENT	HCRM	PAGE
\$50	5 11	2,12
\$51	5 12	2,12
\$52	9 11	3,14
\$53	9 12	3,14
\$54	- -	-
\$55	- -	-
\$56	- -	-
\$57	8 0	3,7
\$58	5 0	2,11
\$59	- -	-
\$5A	- -	-
\$5B	- -	-
\$5C	- -	-
\$5D	- -	-
\$5E	- -	-
\$5F	- -	-

EVENT	HCRM	PAGE
\$60	- -	-
\$61	- -	-
\$62	- -	-
\$63	- -	-
\$64	- -	-
\$65	- -	-
\$66	- -	-
\$67	3 0	1,13
\$68	- -	-
\$69	- -	-
\$6A	- -	-
\$6B	- -	-
\$6C	- -	-
\$6D	- -	-
\$6E	- -	-
\$6F	- -	-

EVENT	HCRM	PAGE
\$70	9 3	3,9
\$71	- -	-
\$72	10 9	4,12
\$73	- -	-
\$74	- -	-
\$75	- -	-
\$76	- -	-
\$77	3 1	1,13
\$78	- -	-
\$79	6 7	2,13
\$7A	5 3	2,10
\$7B	3 5	1,9
\$7C	6 0	2,7
\$7D	8 13	3,12
\$7E	10 10	4,12
\$7F	9 1	3,9

EVENT	HCRM	PAGE
\$80	16 15	6,13
\$81	4 5	2,7
\$82	5 14	2,12
\$83	4 9	2,12
\$84	7 10	3,12
\$85	16 6	6,13
\$86	2 8	1,10
\$87	1 7	1,13
\$88	7 0	3
\$89	2 9	1,10
\$8A	- -	-
\$8B	- -	-
\$8C	6 2	2,7
\$8D	5 13	2,12
\$8E	13 6	5,13
\$8F	1 15	1,14

EVENT	HCRM	PAGE
\$90	16 4	6,13
\$91	16 5	6,13
\$92	9 2	3,12
\$93	16 8	6,13
\$94	18 9	6,13
\$95	7 9	3,12
\$96	9 8	3,12
\$97	9 9	3,12
\$98	9 10	3,12
\$99	8 8	3,7
\$9A	8 9	3,12
\$9B	8 10	3,12
\$9C	8 11	3,12
\$9D	8 12	3,12
\$9E	9 7	3,12
\$9F	8 15	3,12

EVENT	HCRM	PAGE
\$A0	6 4	2,13
\$A1	6 5	2,13
\$A2	6 11	2,12
\$A3	4 7	2,12
\$A4	4 8	2,12
\$A5	13 1	5,13
\$A6	2 3	1,13
\$A7	11 1	UNK
\$A8	11 14	4
\$A9	10 15	4,7
\$AA	- -	-
\$AB	- -	-
\$AC	14 14	5,13
\$AD	2 13	1,11
\$AE	13 5	5,13
\$AF	8 3	3,12

EVENT	HCRM	PAGE
\$B0	11 3	4,9
\$B1	11 4	4,9
\$B2	6 13	2,13
\$B3	5 4	2,10
\$B4	3 2	1,11
\$B5	6 14	2,7
\$B6	8 14	3,12
\$B7	- -	-
\$B8	12 11	4
\$B9	12 7	4
\$BA	1 14	1,15
\$BB	12 4	4
\$BC	12 5	4
\$BD	12 13	4,12
\$BE	13 11	5,13
\$BF	13 12	5,13

EVENT	HCRM	PAGE
\$C0	- -	-
\$C1	- -	-
\$C2	- -	-
\$C3	- -	-
\$C4	- -	-
\$C5	- -	-
\$C6	- -	-
\$C7	- -	-
\$C8	- -	-
\$C9	- -	-
\$CA	- -	-
\$CB	- -	-
\$CC	- -	-
\$CD	- -	-
\$CE	- -	-
\$CF	- -	-

EVENT	HCRM	PAGE
\$D0	- -	-
\$D1	- -	-
\$D2	- -	-
\$D3	- -	-
\$D4	- -	-
\$D5	- -	-
\$D6	- -	-
\$D7	- -	-
\$D8	- -	-
\$D9	- -	-
\$DA	6 3	2,9
\$DB	- -	-
\$DC	- -	-
\$DD	6 1	2,9
\$DE	15 15	6,13
\$DF	- -	-

EVENT	HCRM	PAGE
\$E0	15 4	6,13
\$E1	15 5	6,13
\$E2	15 6	6,13
\$E3	15 7	6,13
\$E4	9 6	3,13
\$E5	- -	-
\$E6	3 7	1,11
\$E7	1 13	1,13
\$E8	4 11	2
\$E9	15 8	6,13
\$EA	13 10	5,13
\$EB	- -	-
\$EC	- -	-
\$ED	4 12	2,11
\$EE	- -	-
\$EF	1 12	1,11

EVENT	HCRM	PAGE
\$F0	- -	-
\$F1	14 13	5,13
\$F2	- -	-
\$F3	11 9	4,7
\$F4	- -	-
\$F5	- -	-
\$F6	10 5	4,7
\$F7	12 9	4,7
\$F8	- -	-
\$F9	- -	-
\$FA	12 14	4,7
\$FB	- -	-
\$FC	- -	-
\$FD	- -	-
\$FE	- -	-
\$FF	- -	-

ITEM NO.	PART NO.	DESCRIPTION or SIZE	QTY. REQ.
PARTS LIST			
UNLESS OTHERWISE SPECIFIED		ORIGINATOR	Mike Kuplic 8-27-99
FRACTIONS	DECIMALS	ANGLES	DRAWN
+	+	+	Mike Kuplic 8-27-99
-	-	-	LAST REVISED
		APPROVED	Mike Kuplic 8-31-21
		USED ON	-
		TEVATRON CLOCK GENERATOR	
		Source Reference:	
FERMI NATIONAL ACCELERATOR LABORATORY UNITED STATES DEPARTMENT OF ENERGY			
TEVATRON CLOCK INTERCONNECT TABLE OF CONTENTS			
SCALE		DRAWING NUMBER	REV.
1:1		Page 0 of 15	A

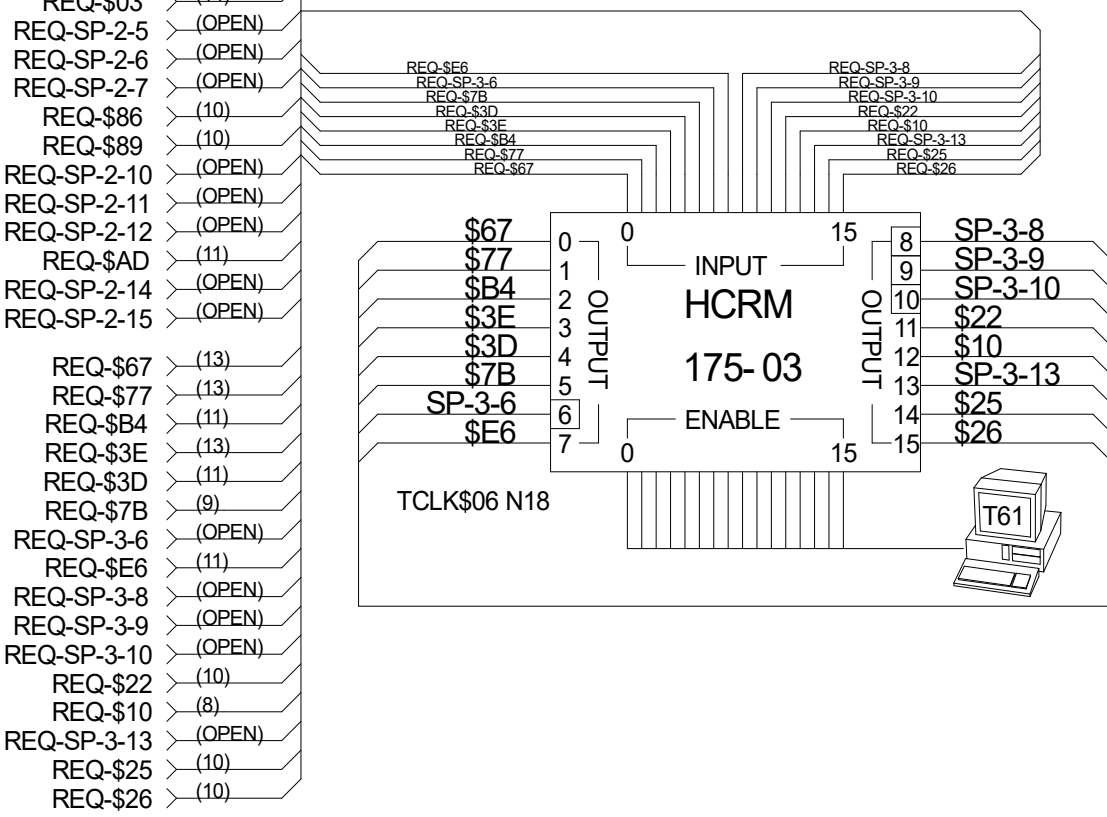
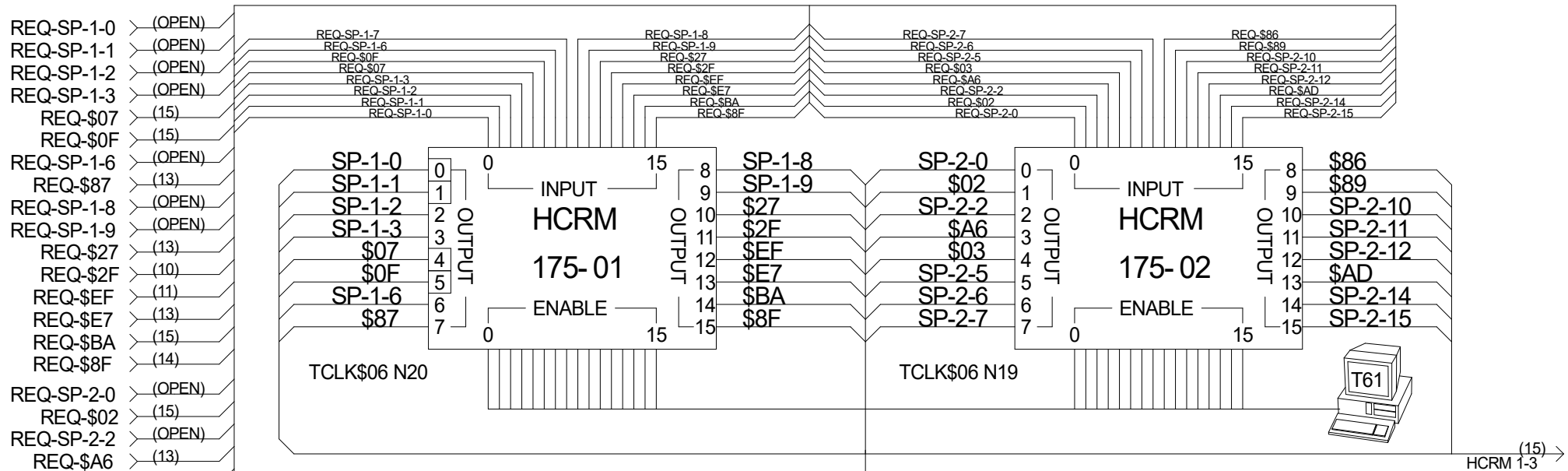

NOTE: OUTPUT CHANNEL NUMBERS ENCLOSED IN BOXES INDICATE HARDWARE-PERMANENTLY ENABLED EVENTS

REQUEST MODULE PRIORITY SEQUENCE:
 16,13,15,14,1,6,2,3,4,5,7,8,9,10,11,12

ITEM NO.	PART NO.	DESCRIPTION or SIZE	QTY. REQ.
PARTS LIST			
UNLESS OTHERWISE SPECIFIED		ORIGINATOR	D. Dupuis
			Pre Dirt
FRACTIONS	DECIMALS	ANGLES	DRAWN
+	+	+	Mike Kuplic
-	-	-	LAST REVISED
			Mike Kuplic
			8-31-21
		APPROVED	-
		USED ON	
		TEV CLOCK GENERATION	
		Source Reference:	
		TCLK1.SCH	
FERMI NATIONAL ACCELERATOR LABORATORY			
UNITED STATES DEPARTMENT OF ENERGY			
TEVATRON CLOCK INTERCONNECT EVENT REQUEST MODULES			
SCALE	DRAWING NUMBER		REV.
1:1	Page 1 of 15		A

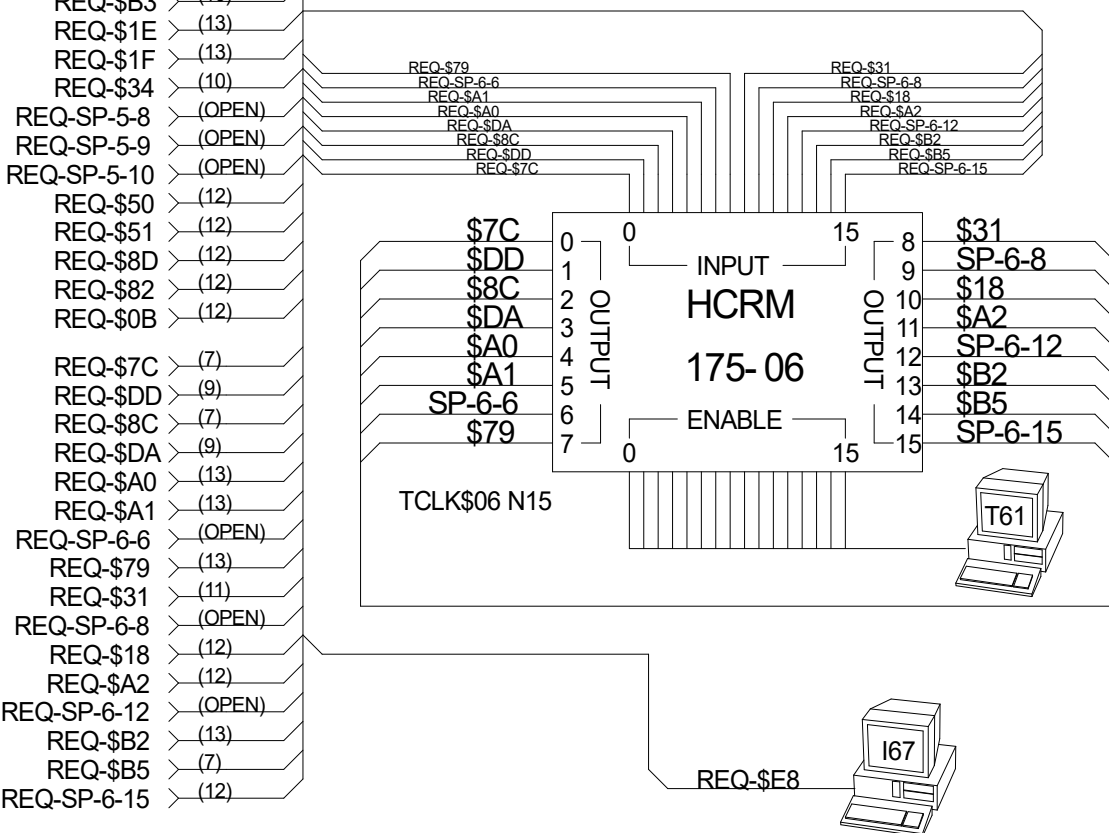
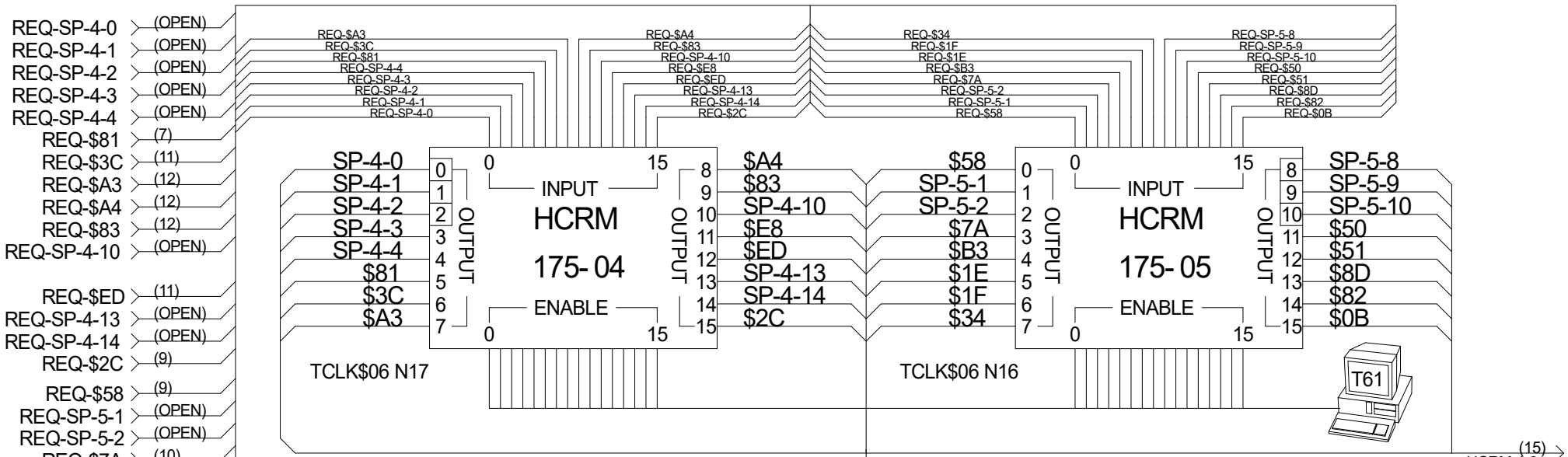

NOTE: OUTPUT CHANNEL NUMBERS ENCLOSED IN BOXES INDICATE HARDWARE-PERMANENTLY ENABLED EVENTS

REQUEST MODULE PRIORITY SEQUENCE:
16,13,15,14,1,6,2,3,4,5,7,8,9,10,11,12

ITEM NO.	PART NO.	DESCRIPTION or SIZE	QTY. REQ.
PARTS LIST			
UNLESS OTHERWISE SPECIFIED		ORIGINATOR	D. Dupuis
			Pre Dirt
FRACTIONS	DECIMALS	ANGLES	DRAWN
+	+	+	Mike Kuplic
-	-	-	LAST REVISED
			Mike Kuplic
		APPROVED	
		USED ON	
		TEV CLOCK GENERATION	
		Source Reference:	
		TCLK2.SCH	
FERMI NATIONAL ACCELERATOR LABORATORY			
UNITED STATES DEPARTMENT OF ENERGY			
TEVATRON CLOCK INTERCONNECT EVENT REQUEST MODULES			
SCALE	DRAWING NUMBER		REV.
1:1	Page 2 of 15		A

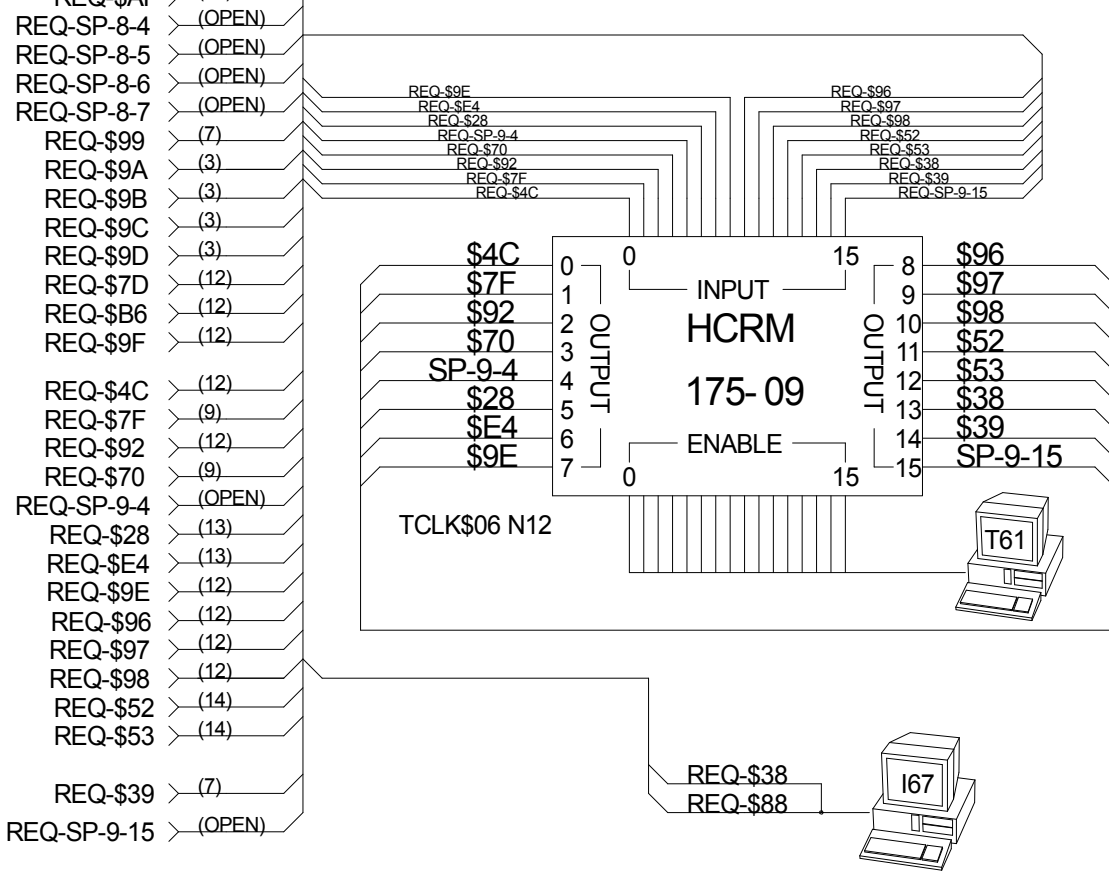
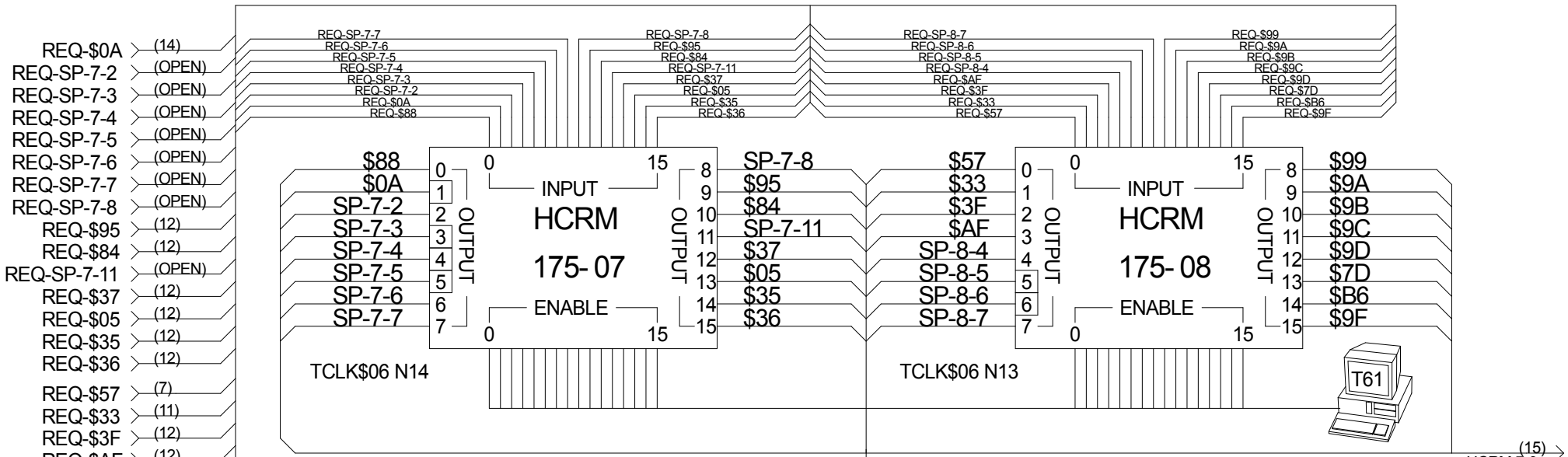

NOTE: OUTPUT CHANNEL NUMBERS ENCLOSED IN BOXES INDICATE HARDWARE-PERMANENTLY ENABLED EVENTS

REQUEST MODULE PRIORITY SEQUENCE:
16,13,15,14,1,6,2,3,4,5,7,8,9,10,11,12

ITEM NO.	PART NO.	DESCRIPTION or SIZE	QTY. REQ.
PARTS LIST			
UNLESS OTHERWISE SPECIFIED		ORIGINATOR	D. Dupuis
			Pre Dirt
FRACTIONS	DECIMALS	ANGLES	DRAWN
+	+	+	Mike Kuplic
-	-	-	7/30/99
		LAST REVISED	Mike Kuplic
			8-20-18
		APPROVED	
		USED ON	
		TEV CLOCK GENERATION	
		Source Reference:	
		TCLK3.SCH	
FERMI NATIONAL ACCELERATOR LABORATORY			
UNITED STATES DEPARTMENT OF ENERGY			
TEVATRON CLOCK INTERCONNECT EVENT REQUEST MODULES			
SCALE	DRAWING NUMBER		REV.
1:1	Page 3 of 15		A

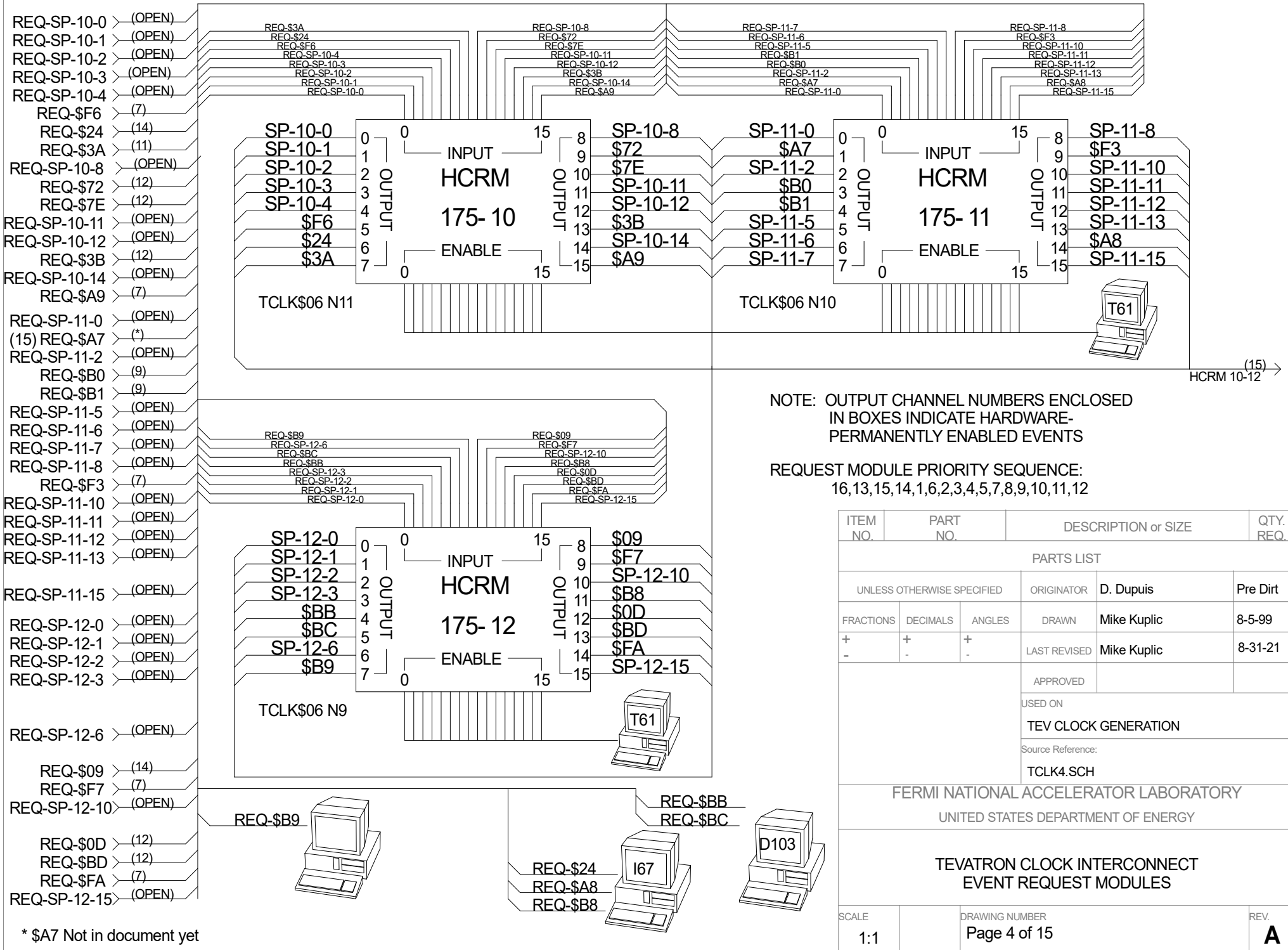

NOTE: OUTPUT CHANNEL NUMBERS ENCLOSED IN BOXES INDICATE HARDWARE-PERMANENTLY ENABLED EVENTS

REQUEST MODULE PRIORITY SEQUENCE:
16,13,15,14,1,6,2,3,4,5,7,8,9,10,11,12

ITEM NO.	PART NO.	DESCRIPTION or SIZE	QTY. REQ.
PARTS LIST			
UNLESS OTHERWISE SPECIFIED		ORIGINATOR	D. Dupuis
			Pre Dirt
FRACTIONS	DECIMALS	ANGLES	DRAWN
+	+	+	Mike Kuplic
-	-	-	LAST REVISED
			Mike Kuplic
			8-5-99
		APPROVED	
		USED ON	
		TEV CLOCK GENERATION	
		Source Reference:	
		TCLK4.SCH	
FERMI NATIONAL ACCELERATOR LABORATORY			
UNITED STATES DEPARTMENT OF ENERGY			
TEVATRON CLOCK INTERCONNECT EVENT REQUEST MODULES			
SCALE		DRAWING NUMBER	
1:1		Page 4 of 15	
			REV.
			A

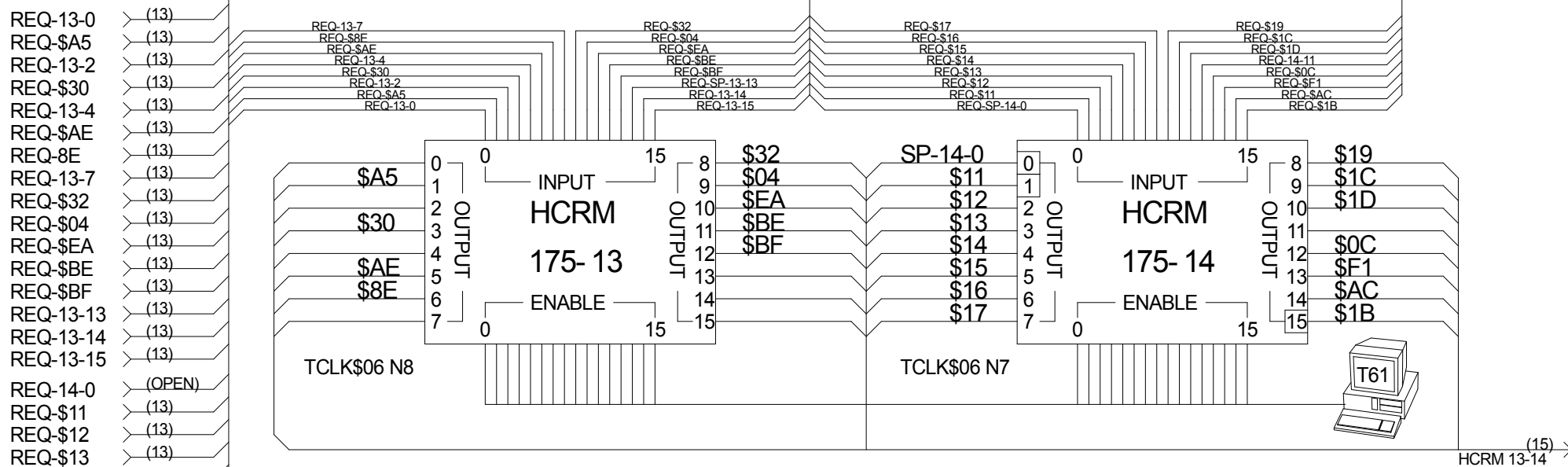

(15) →
HCRM 13-14

NOTE: OUTPUT CHANNEL NUMBERS ENCLOSED
IN BOXES INDICATE HARDWARE-
PERMANENTLY ENABLED EVENTS

REQUEST MODULE PRIORITY SEQUENCE:
16,13,15,14,1,6,2,3,4,5,7,8,9,10,11,12

- REQ-13-0 > (13)
- REQ-\$A5 > (13)
- REQ-13-2 > (13)
- REQ-\$30 > (13)
- REQ-13-4 > (13)
- REQ-\$AE > (13)
- REQ-8E > (13)
- REQ-13-7 > (13)
- REQ-\$32 > (13)
- REQ-\$04 > (13)
- REQ-\$EA > (13)
- REQ-\$BE > (13)
- REQ-\$BF > (13)
- REQ-13-13 > (13)
- REQ-13-14 > (13)
- REQ-13-15 > (13)
- REQ-14-0 > (OPEN)
- REQ-\$11 > (13)
- REQ-\$12 > (13)
- REQ-\$13 > (13)
- REQ-\$14 > (13)
- REQ-\$15 > (13)
- REQ-\$16 > (13)
- REQ-\$17 > (13)
- REQ-\$19 > (13)
- REQ-\$1C > (13)
- REQ-\$1D > (13)
- REQ-14-11 > (13)
- REQ-\$0C > (13)
- REQ-\$F1 > (13)
- REQ-\$AC > (13)
- REQ-\$1B > (13)

ITEM NO.	PART NO.	DESCRIPTION or SIZE	QTY. REQ.
PARTS LIST			
UNLESS OTHERWISE SPECIFIED		ORIGINATOR	D. Dupuis
			Pre Dirt
FRACTIONS	DECIMALS	ANGLES	DRAWN
+	+	+	Mike Kuplic
-	-	-	8-5-99
		LAST REVISED	Mike Kuplic
			6-12-17
		APPROVED	*
		USED ON	
		TEV CLOCK GENERATION	
		Source Reference: TCLK5.SCH	
FERMI NATIONAL ACCELERATOR LABORATORY			
UNITED STATES DEPARTMENT OF ENERGY			
TEVATRON CLOCK INTERCONNECT EVENT REQUEST MODULES			
SCALE	DRAWING NUMBER		REV.
1:1	Page 5 of 15		A

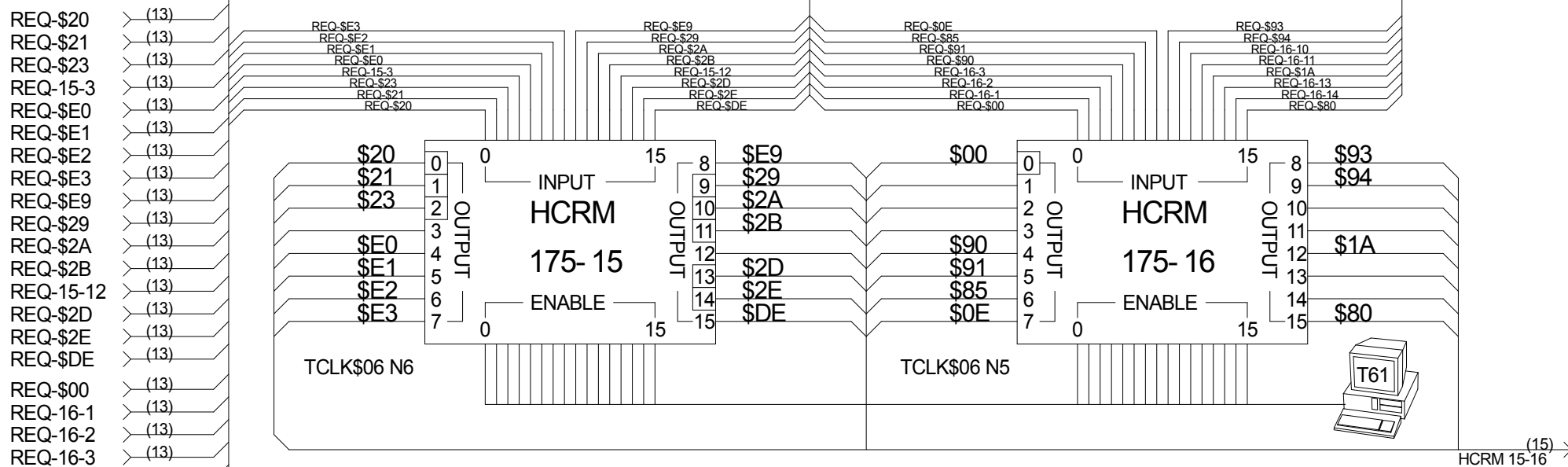

- REQ-\$20 > (13)
- REQ-\$21 > (13)
- REQ-\$23 > (13)
- REQ-15-3 > (13)
- REQ-\$E0 > (13)
- REQ-\$E1 > (13)
- REQ-\$E2 > (13)
- REQ-\$E3 > (13)
- REQ-\$E9 > (13)
- REQ-\$29 > (13)
- REQ-\$2A > (13)
- REQ-\$2B > (13)
- REQ-15-12 > (13)
- REQ-\$2D > (13)
- REQ-\$2E > (13)
- REQ-\$DE > (13)
- REQ-\$00 > (13)
- REQ-16-1 > (13)
- REQ-16-2 > (13)
- REQ-16-3 > (13)
- REQ-\$90 > (13)
- REQ-\$91 > (13)
- REQ-\$85 > (13)
- REQ-\$0E > (13)
- REQ-\$93 > (13)
- REQ-\$94 > (13)
- REQ-16-10 > (13)
- REQ-16-11 > (13)
- REQ-\$1A > (13)
- REQ-16-13 > (13)
- REQ-16-14 > (13)
- REQ-\$80 > (13)

NOTE: OUTPUT CHANNEL NUMBERS ENCLOSED
IN BOXES INDICATE HARDWARE-
PERMANENTLY ENABLED EVENTS

REQUEST MODULE PRIORITY SEQUENCE:
16,13,15,14,1,6,2,3,4,5,7,8,9,10,11,12

ITEM NO.	PART NO.	DESCRIPTION or SIZE	QTY. REQ.
PARTS LIST			
UNLESS OTHERWISE SPECIFIED		ORIGINATOR	D. Dupuis
			Pre Dirt
FRACTIONS	DECIMALS	ANGLES	DRAWN
+	+	+	Mike Kuplic
-	-	-	8-5-99
		LAST REVISED	Mike Kuplic
			8-15-18
		APPROVED	*

		USED ON	
		TEV CLOCK GENERATION	
		Source Reference:	
		TCLK6.SCH	
FERMI NATIONAL ACCELERATOR LABORATORY			
UNITED STATES DEPARTMENT OF ENERGY			
TEVATRON CLOCK INTERCONNECT EVENT REQUEST MODULES			
SCALE	DRAWING NUMBER		REV.
1:1	Page 6 of 15		A

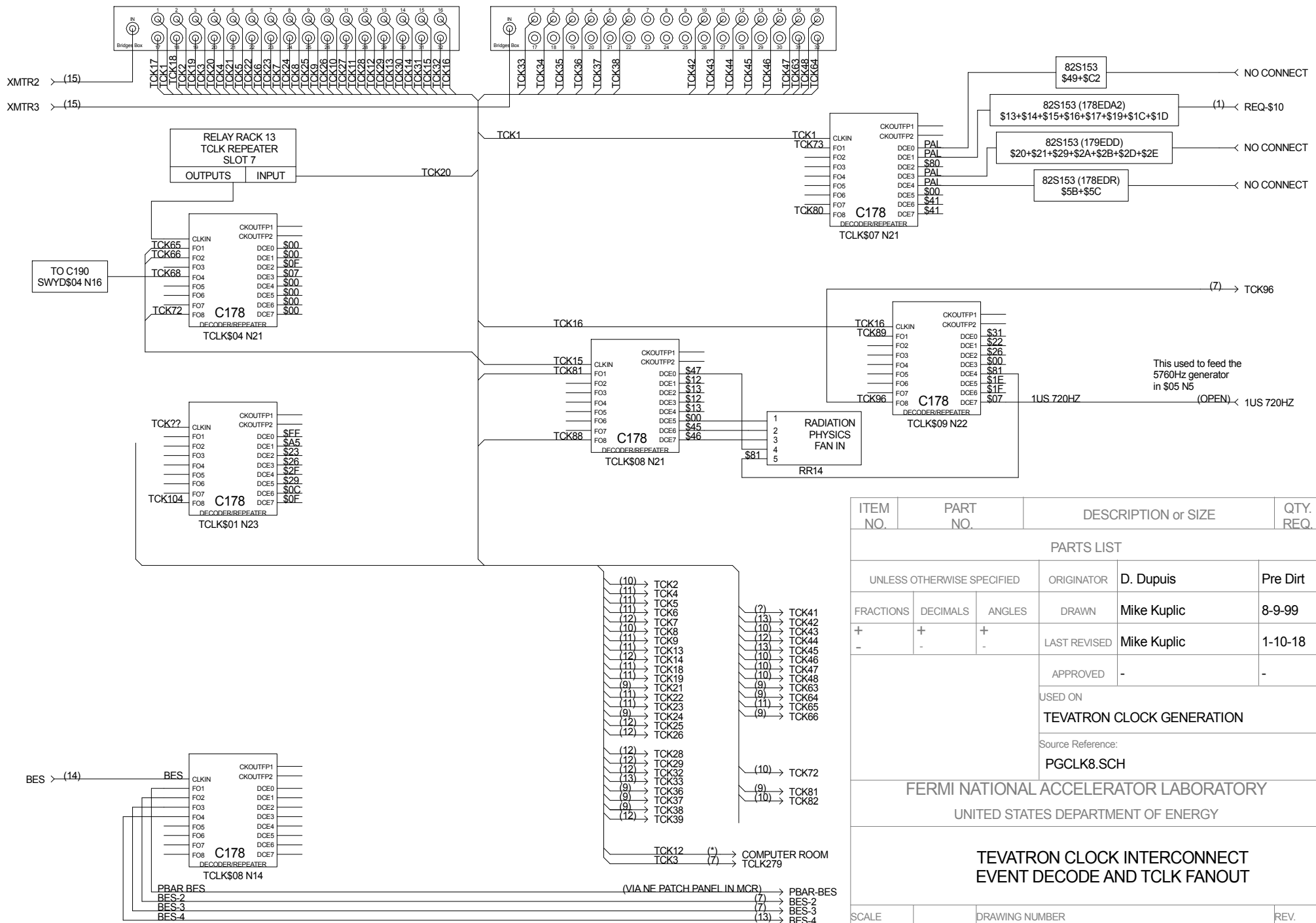

ITEM NO.	PART NO.	DESCRIPTION or SIZE	QTY. REQ.
PARTS LIST			
UNLESS OTHERWISE SPECIFIED		ORIGINATOR	D. Dupuis
			Pre Dirt
FRACTIONS	DECIMALS	ANGLES	DRAWN
			Mike Kuplic
			8-9-99
+	+	+	LAST REVISED
-	-	-	Mike Kuplic
			1-10-18
		APPROVED	-
USED ON			
TEVATRON CLOCK GENERATION			
Source Reference:			
PGCLK8.SCH			
FERMI NATIONAL ACCELERATOR LABORATORY			
UNITED STATES DEPARTMENT OF ENERGY			
TEVATRON CLOCK INTERCONNECT EVENT DECODE AND TCLK FANOUT			
SCALE	DRAWING NUMBER		REV.
1:1	Page 8 of 15		A

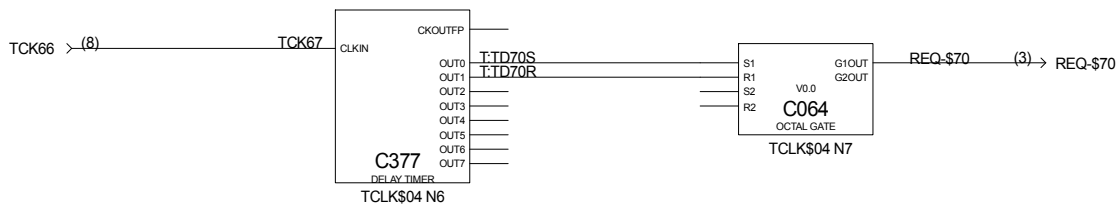
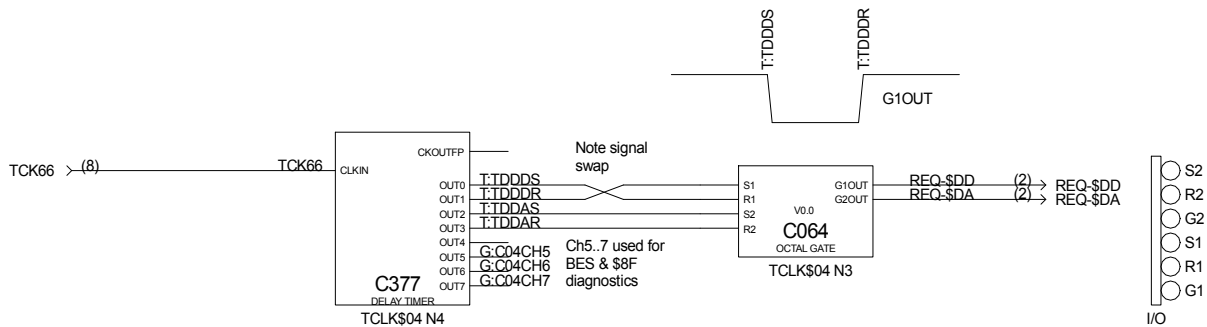
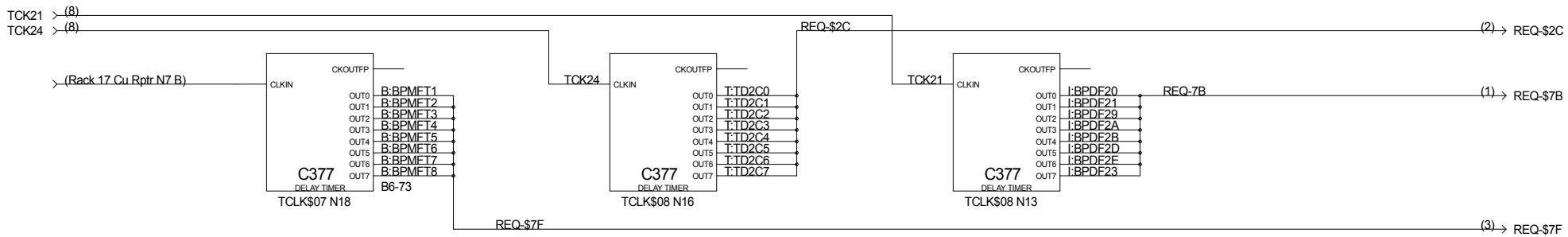

ITEM NO.	PART NO.	DESCRIPTION or SIZE	QTY. REQ.
PARTS LIST			
UNLESS OTHERWISE SPECIFIED		ORIGINATOR	D. Dupuis
			Pre Dirt
FRACTIONS	DECIMALS	ANGLES	DRAWN
+	+	+	Mike Kuplic
-	-	-	LAST REVISED
			M. Kuplic
			10-2-18
		APPROVED	-
USED ON			
TEVATRON CLOCK GENERATION			
Source Reference:			
PGCLK9.SCH			
FERMI NATIONAL ACCELERATOR LABORATORY			
UNITED STATES DEPARTMENT OF ENERGY			
TEVATRON CLOCK INTERCONNECT SPECIALIZED 377 TIMERS			
SCALE	DRAWING NUMBER		REV.
1:1	Page 9 of 15		A

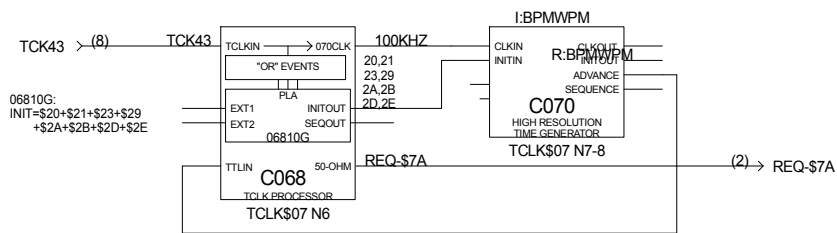
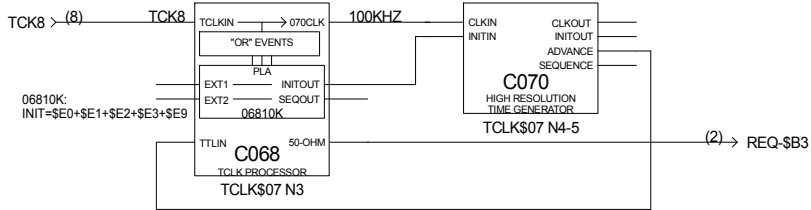
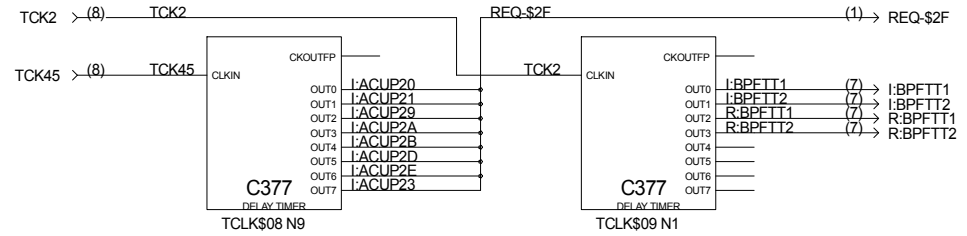
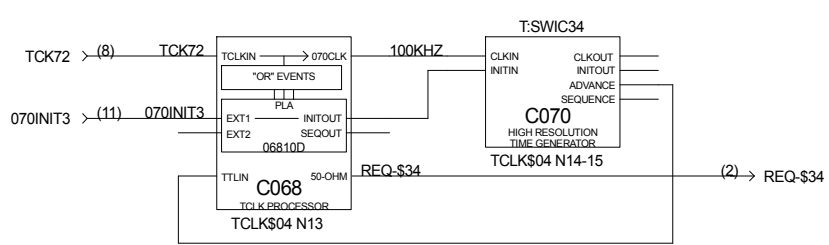
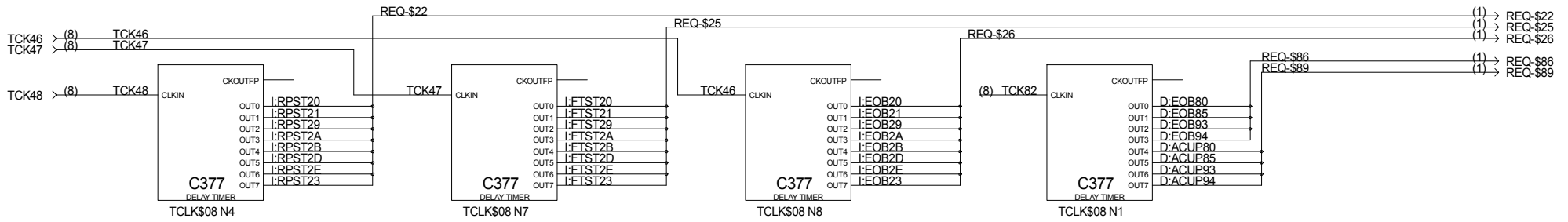

ITEM NO.	PART NO.	DESCRIPTION or SIZE	QTY. REQ.
PARTS LIST			
UNLESS OTHERWISE SPECIFIED		ORIGINATOR	D. Dupuis
			Pre Dirt
FRACTIONS	DECIMALS	ANGLES	DRAWN
+	+	+	Mike Kupic
-	-	-	LAST REVISED
			Mike Kupic
			8-9-99
			8-10-16
		APPROVED	-
USED ON			
TEVATRON CLOCK GENERATION			
Source Reference:			
PGCLK10.SCH			
FERMI NATIONAL ACCELERATOR LABORATORY			
UNITED STATES DEPARTMENT OF ENERGY			
TEVATRON CLOCK INTERCONNECT			
377 TIMERS AND MISC			
SCALE	DRAWING NUMBER		REV.
1:1	Page 10 of 15		A

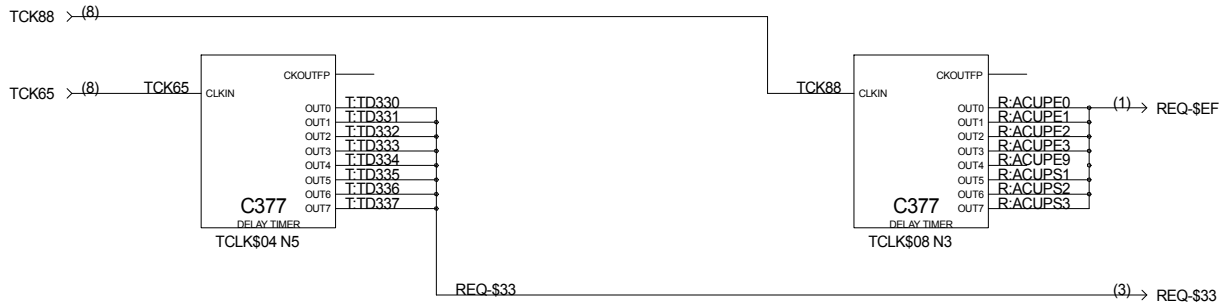
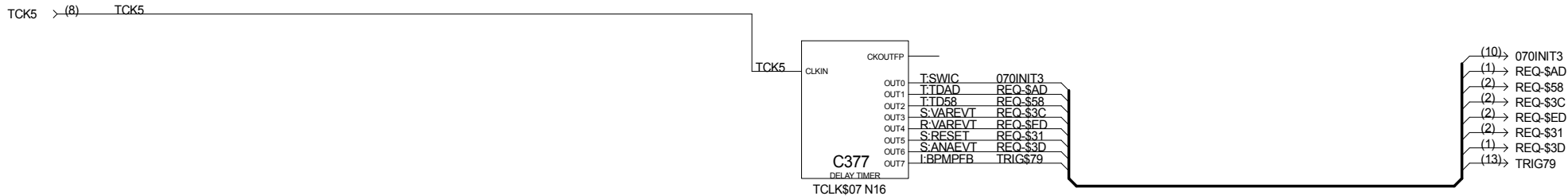
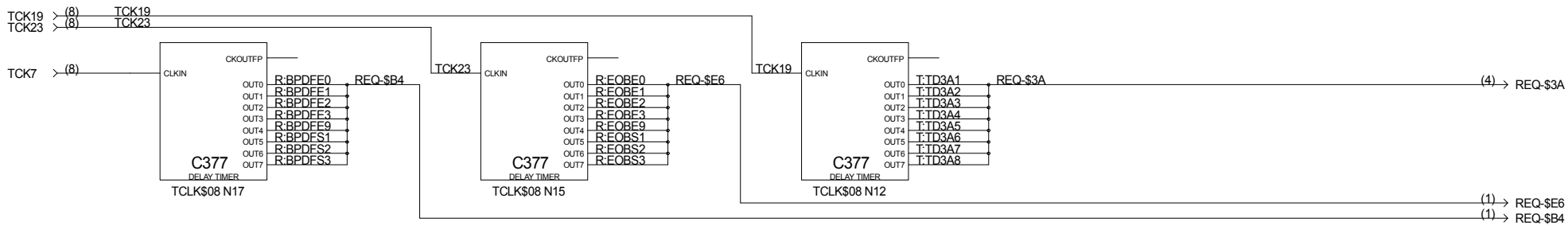

ITEM NO.	PART NO.	DESCRIPTION or SIZE	QTY. REQ.
PARTS LIST			
UNLESS OTHERWISE SPECIFIED		ORIGINATOR	Pre Dirt
FRACTIONS	DECIMALS	ANGLES	DRAWN
+	+	+	Mike Kuplic
-	-	-	LAST REVISED
		APPROVED	Mike Kuplic
		USED ON	1-10-18
		TEVATRON CLOCK GENERATION	
		Source Reference:	
		PGCLK11.SCH	
FERMI NATIONAL ACCELERATOR LABORATORY			
UNITED STATES DEPARTMENT OF ENERGY			
TEVATRON CLOCK INTERCONNECT SPECIALIZED AND STANDARD 377 TIMERS			
SCALE	DRAWING NUMBER		REV.
1:1	Page 11 of 15		A

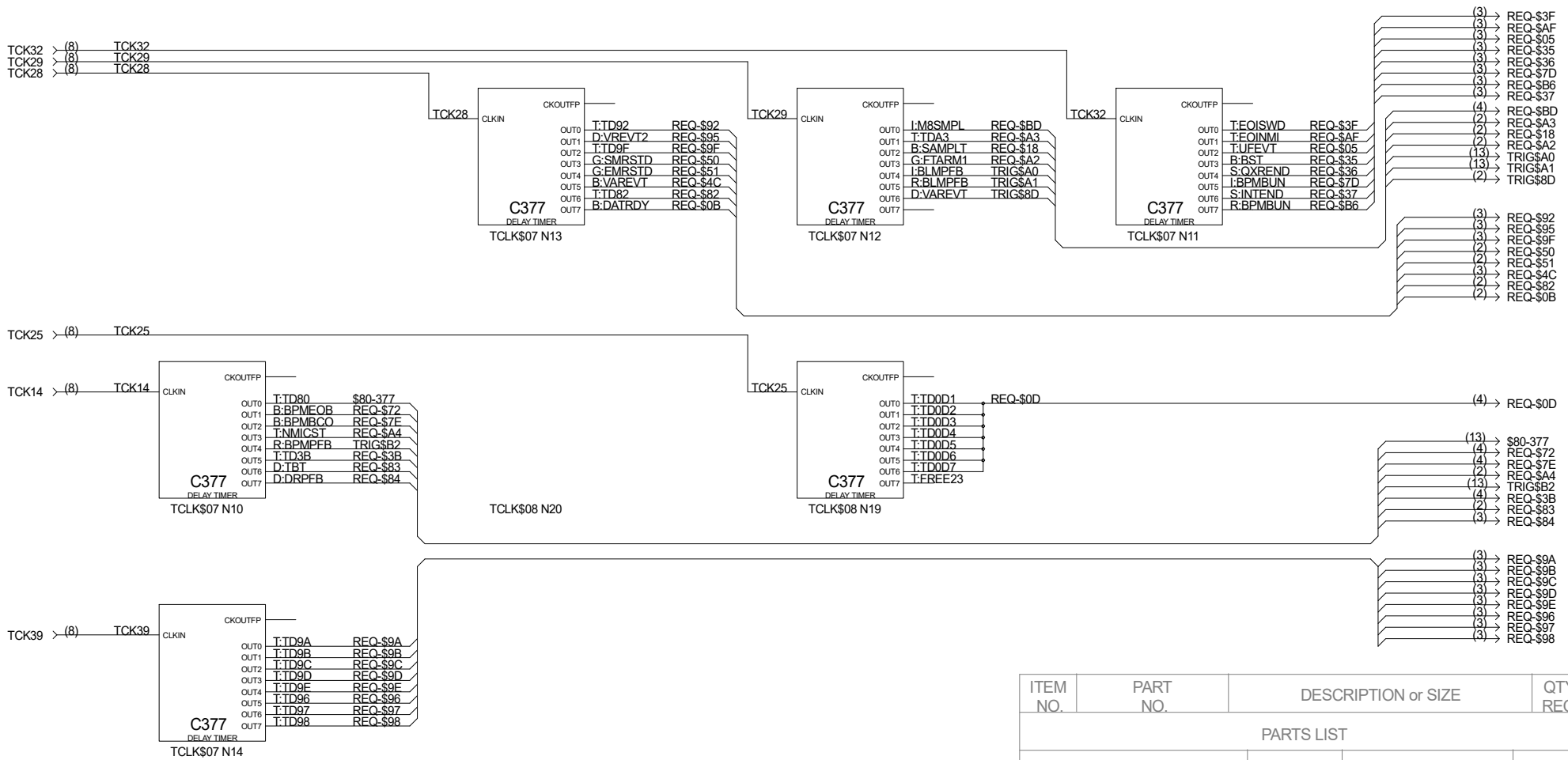

ITEM NO.	PART NO.	DESCRIPTION or SIZE	QTY. REQ.
PARTS LIST			
UNLESS OTHERWISE SPECIFIED		ORIGINATOR	D. Dupuis
			Pre Dirt
FRACTIONS	DECIMALS	ANGLES	DRAWN
+	+	+	Mike Kuplic
-	-	-	8-9-99
		LAST REVISED	Mike Kuplic
			9-9-20
		APPROVED	-
USED ON			
TEVATRON CLOCK GENERATION			
Source Reference:			
PGCLK12.SCH			
FERMI NATIONAL ACCELERATOR LABORATORY			
UNITED STATES DEPARTMENT OF ENERGY			
TEVATRON CLOCK INTERCONNECT STANDARD 377 TIMERS			
SCALE	DRAWING NUMBER		REV.
1:1	Page 12 of 15		A

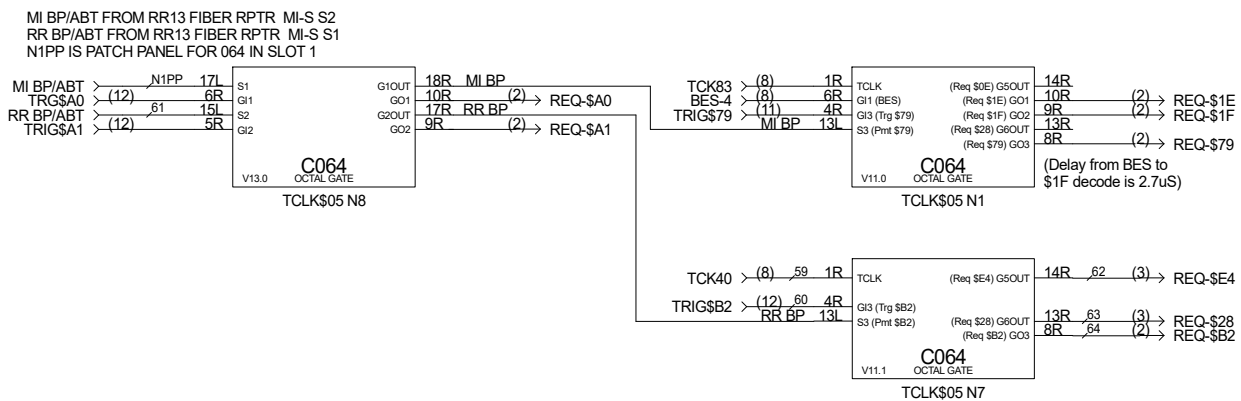
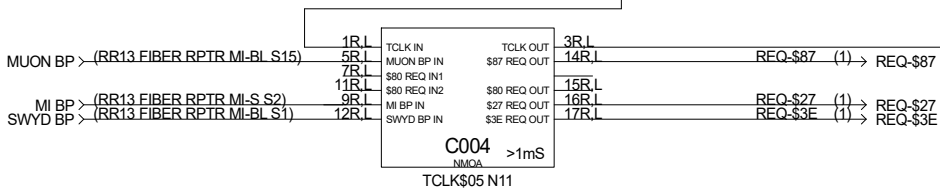
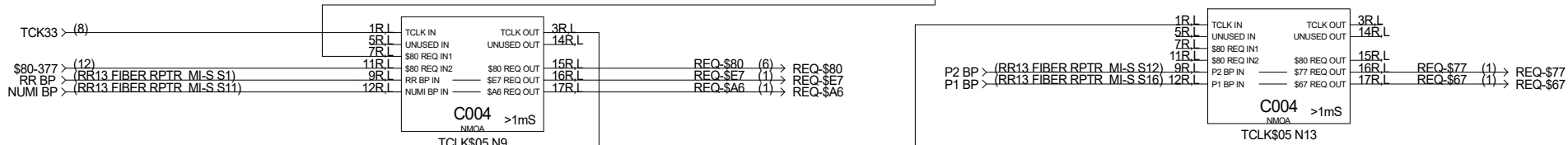
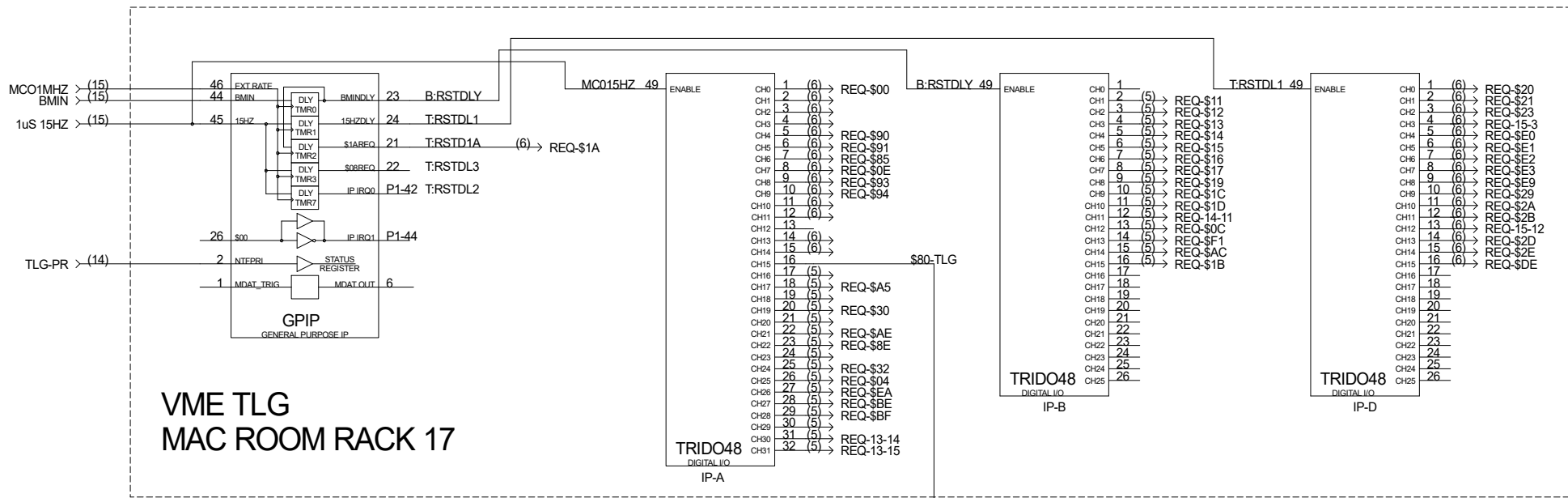

ITEM NO.	PART NO.	DESCRIPTION or SIZE	QTY. REQ.
PARTS LIST			
UNLESS OTHERWISE SPECIFIED		ORIGINATOR	D. Dupuis
		DRAWN	Mike Kupic
		LAST REVISED	Mike Kupic
		APPROVED	-
USED ON			
TEVATRON CLOCK GENERATION			
Source Reference:			
PGCLK13.SCH			
FERMI NATIONAL ACCELERATOR LABORATORY			
UNITED STATES DEPARTMENT OF ENERGY			
TEVATRON CLOCK INTERCONNECT SPECIAL PURPOSE MODULES			
SCALE	DRAWING NUMBER		REV.
1:1	Page 13 of 15		A

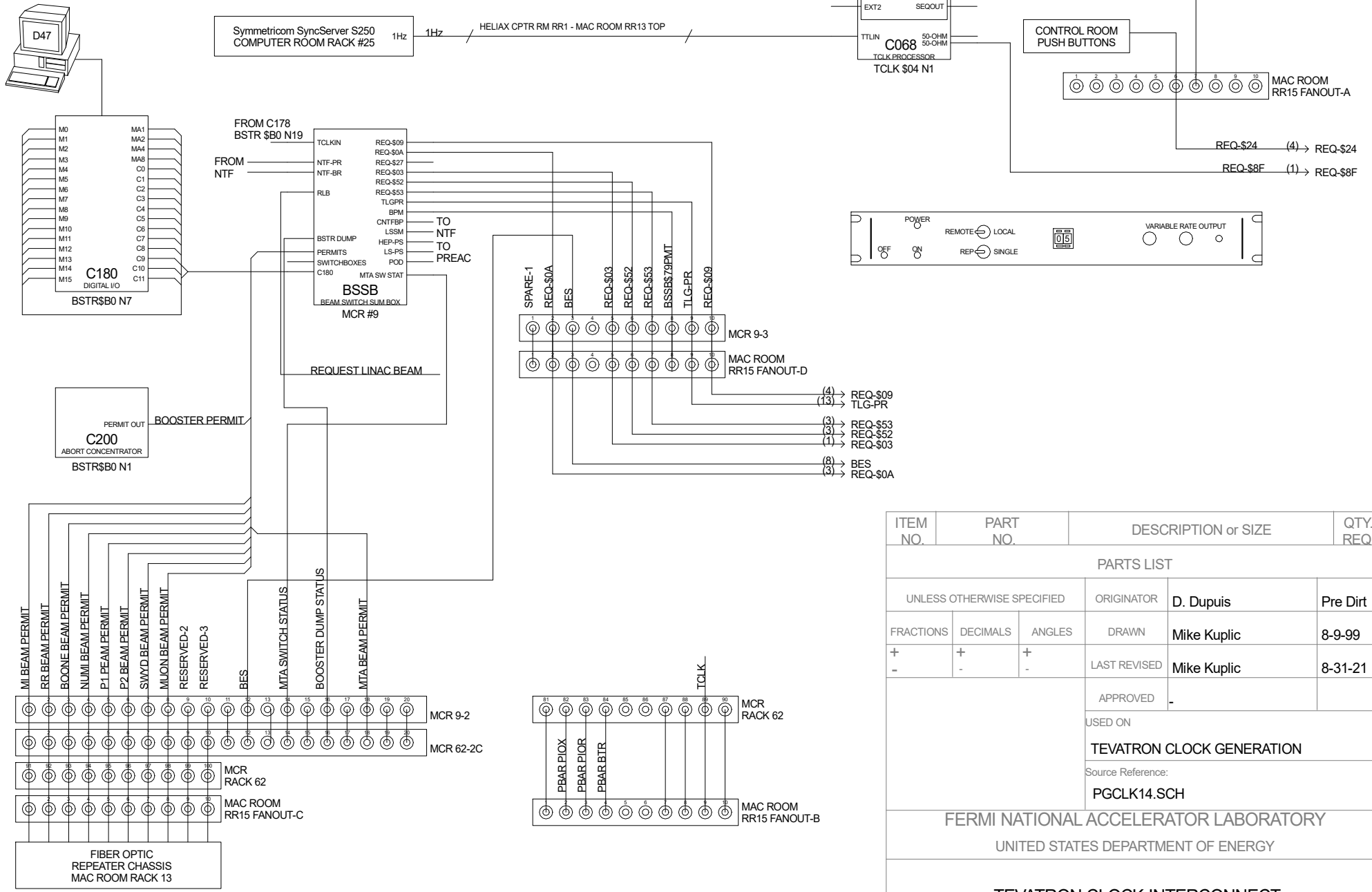

ITEM NO.	PART NO.	DESCRIPTION or SIZE	QTY. REQ.
PARTS LIST			
UNLESS OTHERWISE SPECIFIED		ORIGINATOR	D. Dupuis
			Pre Dirt
FRACTIONS	DECIMALS	ANGLES	DRAWN
+	+	+	Mike Kupic
-	-	-	LAST REVISED
			Mike Kupic
			8-9-99
			8-31-21
		APPROVED	-
USED ON			
TEVATRON CLOCK GENERATION			
Source Reference:			
PGCLK14.SCH			
FERMI NATIONAL ACCELERATOR LABORATORY			
UNITED STATES DEPARTMENT OF ENERGY			
TEVATRON CLOCK INTERCONNECT MAC ROOM PATCH PANELS			
SCALE	DRAWING NUMBER		REV.
1:1	Page 14 of 15		A

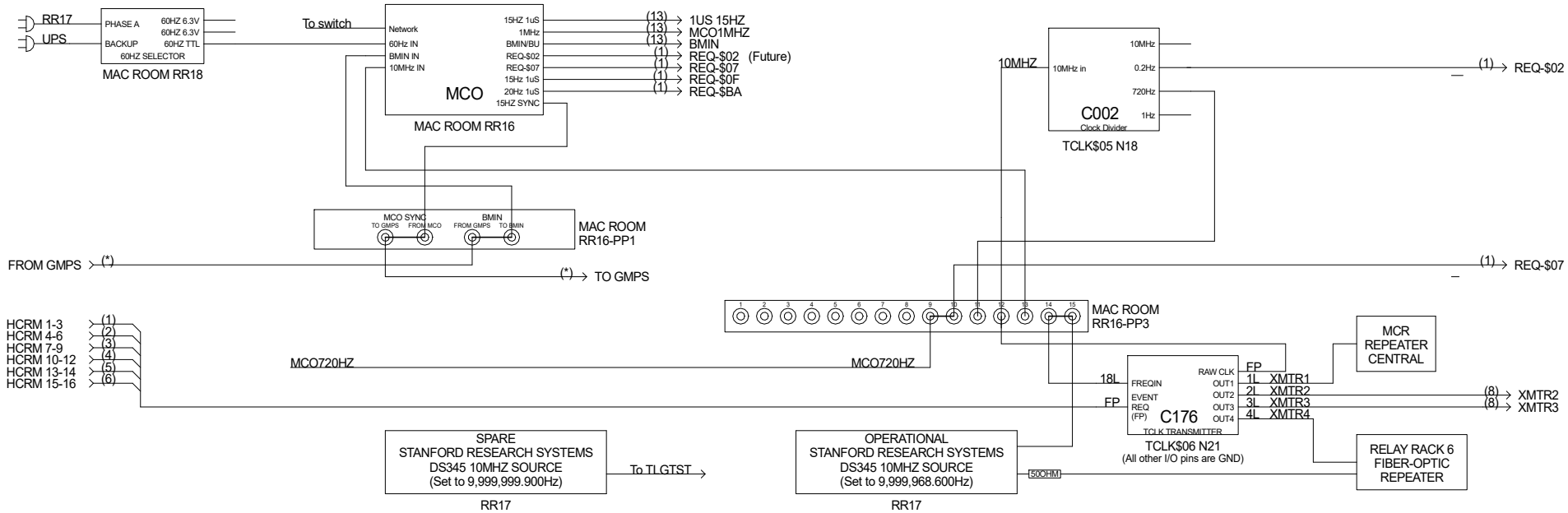

ITEM NO.	PART NO.	DESCRIPTION or SIZE	QTY. REQ.
PARTS LIST			
UNLESS OTHERWISE SPECIFIED		ORIGINATOR	
FRACTIONS	DECIMALS	ANGLES	DRAWN
+	+	+	Mike Kuplic
-	-	-	8-9-99
		LAST REVISED	Mike Kuplic
			10-30-19
		APPROVED	-
		USED ON	
		TEVATRON CLOCK GENERATION	
		Source Reference:	
FERMI NATIONAL ACCELERATOR LABORATORY UNITED STATES DEPARTMENT OF ENERGY			
TEVATRON CLOCK INTERCONNECT FREQUENCY GENERATION			
SCALE	DRAWING NUMBER		REV.
1:1	Page 15 of 15		A