

8

7

6

5

4

3

2

1

D

D

C

C

B

B

A

A

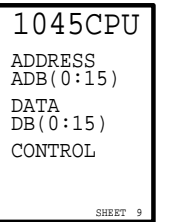
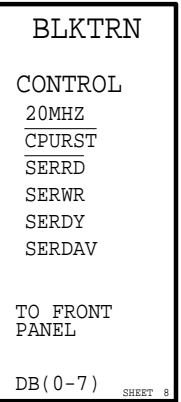
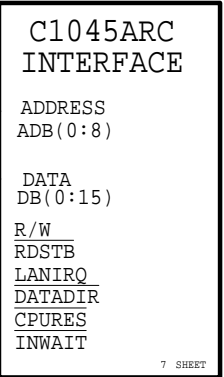
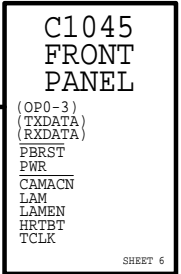
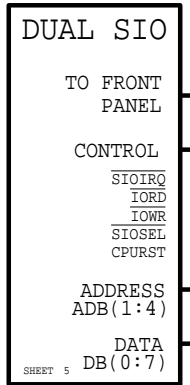
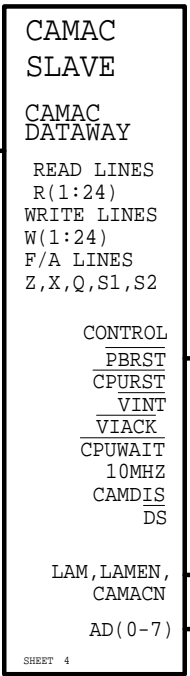
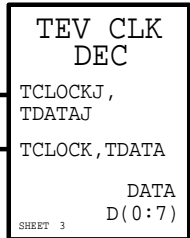
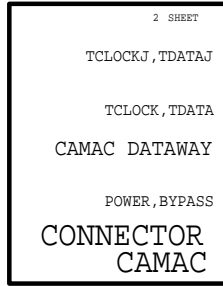

REF. C1045.SCH

DRAWN		DATE	C1045 TOP	
CHECKED	R. FLOOD	9/29/89	SIZE C	DWG. NO. 0880-EC-172840
ISSUED			SCALE	REV.
			SHEET	1 OF 9

8

7

6

5

4

3

2

1

8

7

6

5

4

3

2

1

D

D

C

C

B

B

A

A

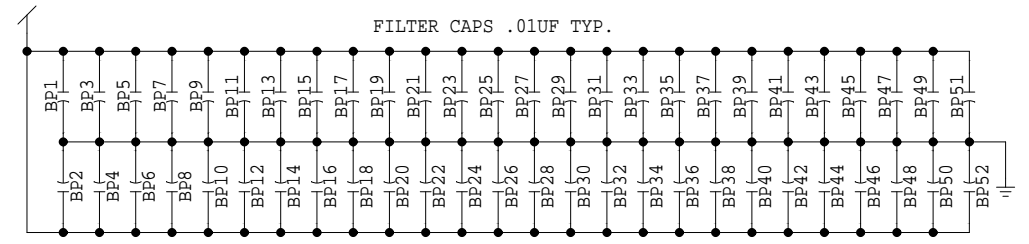
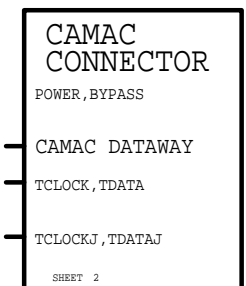
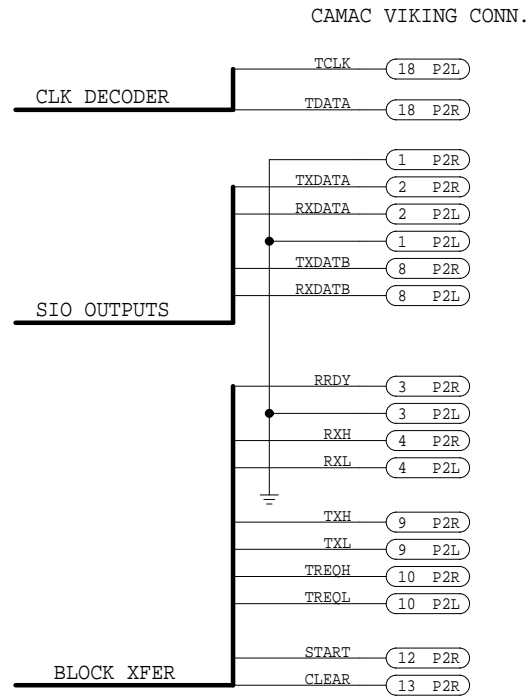
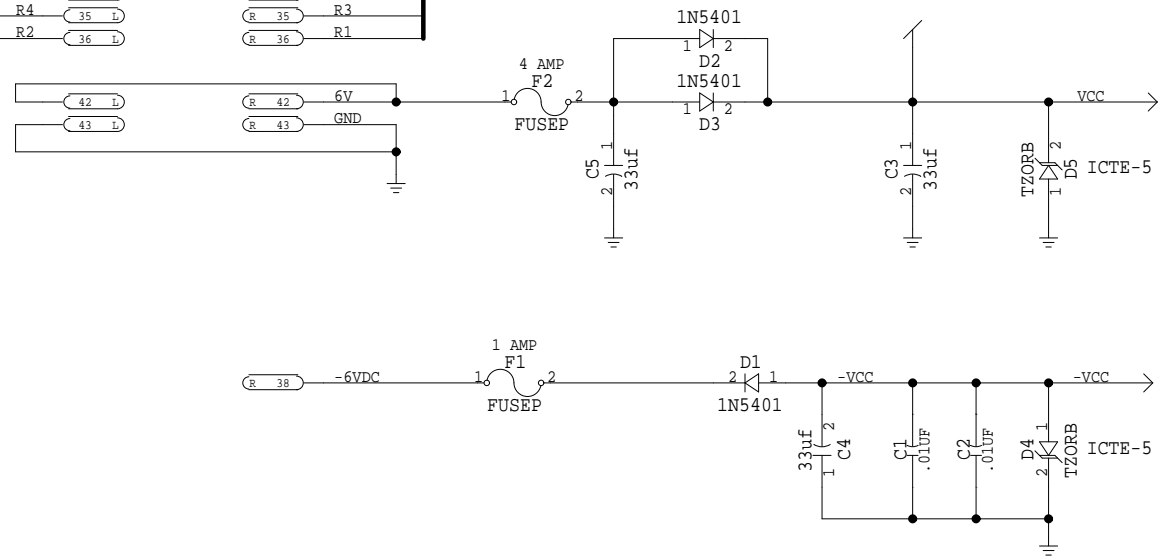
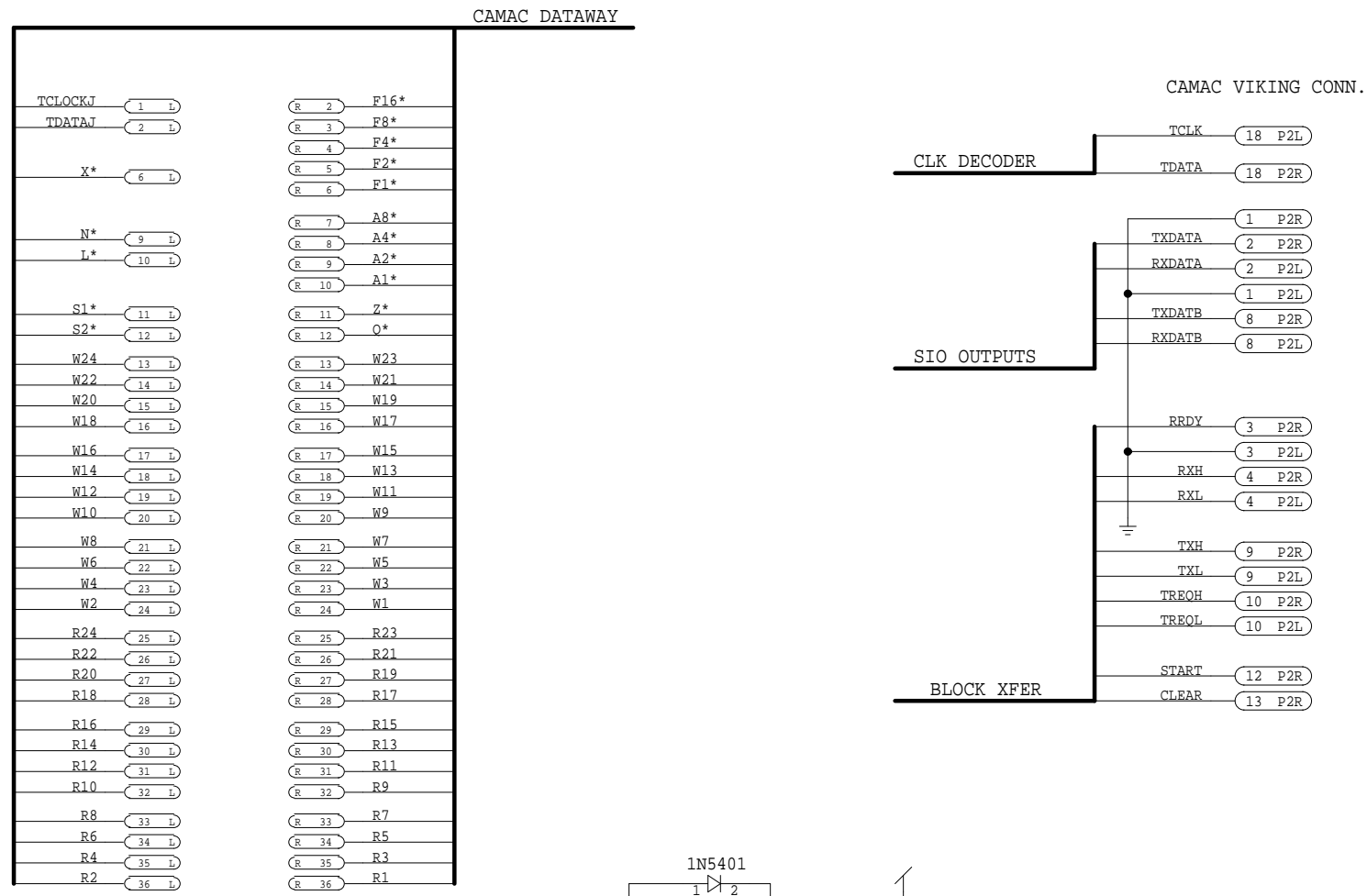

REF. 1045CMCN.SCH

DRAWN R. FLOOD		DATE	1045 CAMAC CONNECTOR	
CHECKED R. FLOOD		12/20/89	SIZE C	DWG. NO. 0880-EC-172840
ISSUED			SCALE	SHEET 2 OF 9

8 7 6 5 4 3 1

D

D

C

C

B

B

A

A

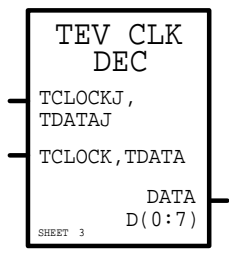
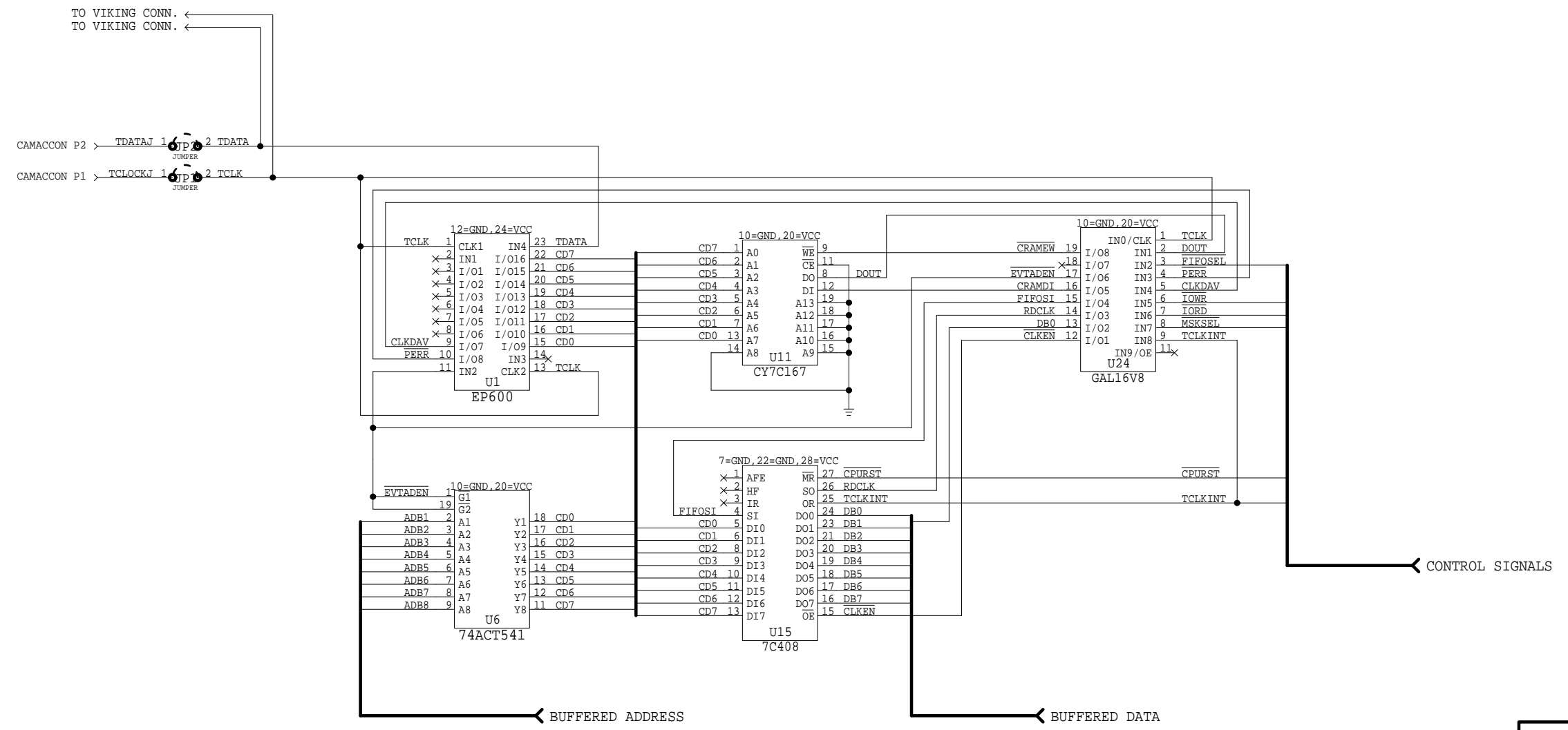

REF. 1045CLK.SCH

DRAWN M. KUPLIC		DATE	C1045 TEV CLK DECODER	
CHECKED R. FLOOD	9/25/89	SIZE	DWG. NO.	REV.
ISSUED		C	0880-EC-172840	
SCALE		SHEET 3 OF 9		

8 7 6 5 4 3 2 1

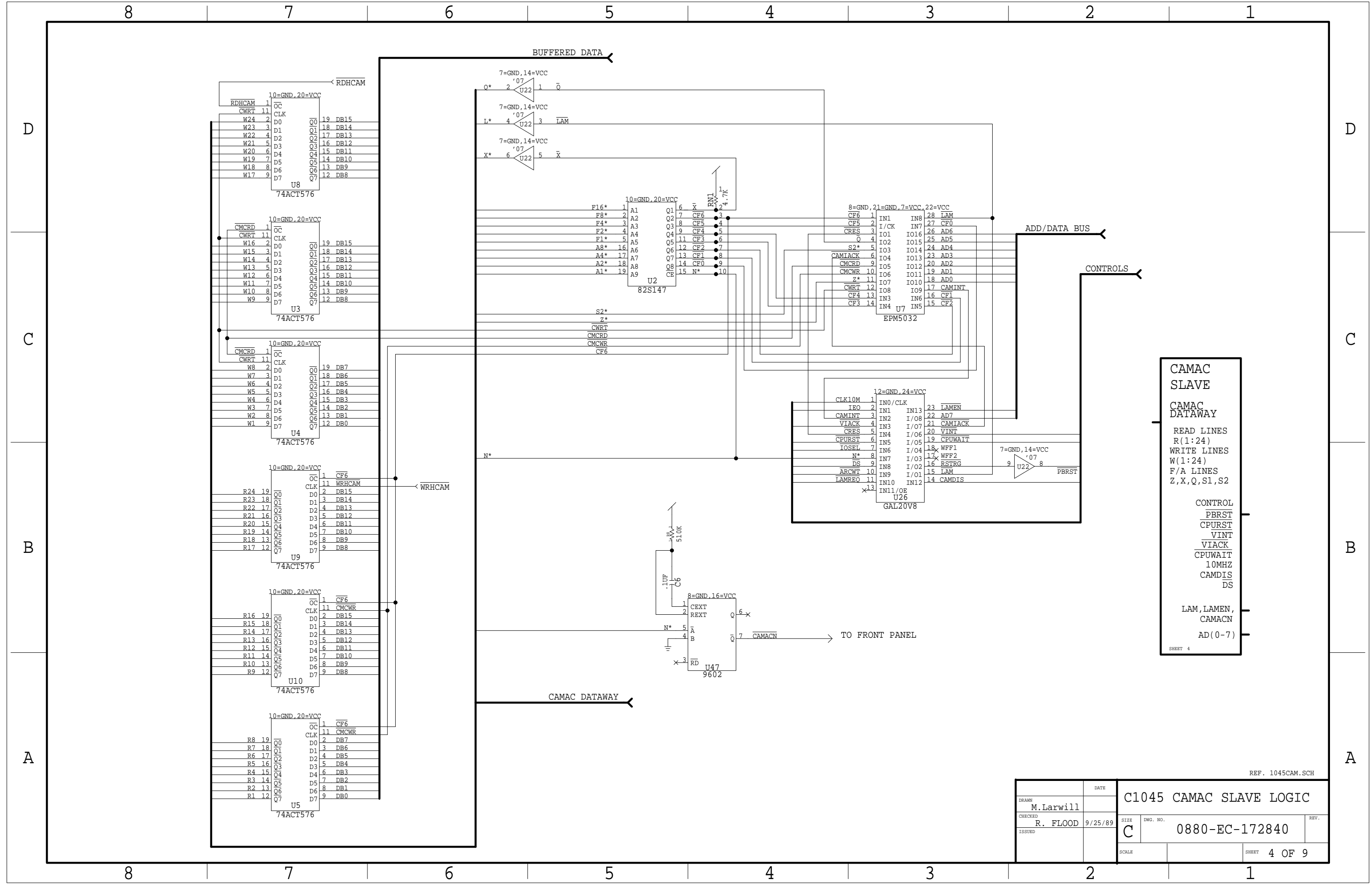

**CAMAC SLAVE**

**CAMAC DATAWAY**

READ LINES  
R(1:24)

WRITE LINES  
W(1:24)

F/A LINES  
Z, X, Q, S1, S2

CONTROL

PBRST

CPURST

VINT

VIACK

CPUWAIT

10MHZ

CAMDIS

DS

LAM, LAMEN,  
CAMACN

AD(0-7)

REF. 1045CAM.SCH

DRAWN	M.Larwill	DATE		C1045 CAMAC SLAVE LOGIC	
CHECKED	R. FLOOD	9/25/89	SIZE	ENG. NO.	REV.
ISSUED			C	0880-EC-172840	
SCALE			SHEET 4 OF 9		

8 7 6 5 4 3 2 1

D

D

C

C

B

B

A

A

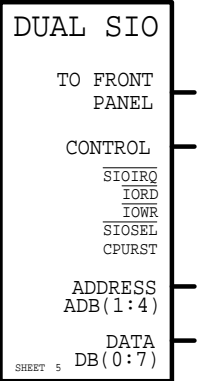
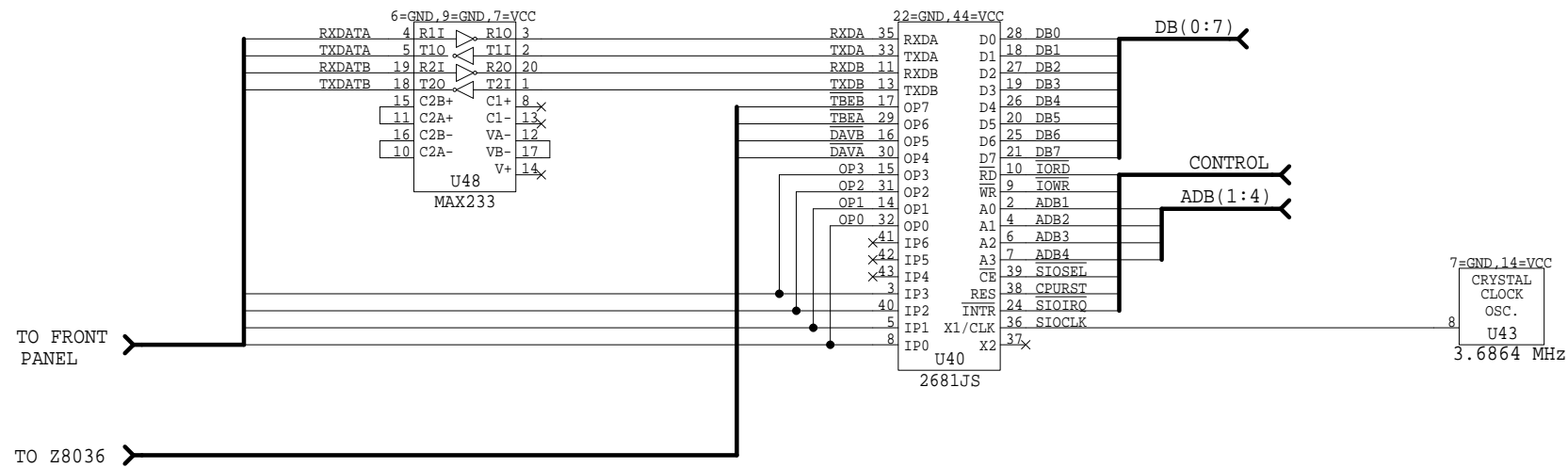

REF. 1045SIO.SCH

DRAWN		DATE		C1045 SIO LOGIC	
R. FLOOD					
CHECKED		9/25/89		SIZE	DWG. NO.
R. FLOOD				C	0880-EC-172840
ISSUED				SCALE	SHEET 5 OF 9
				NONE	

8 7 6 5 4 3 2 1

8 7 6 5 4 3 2 1

D

D

C

C

B

B

A

A

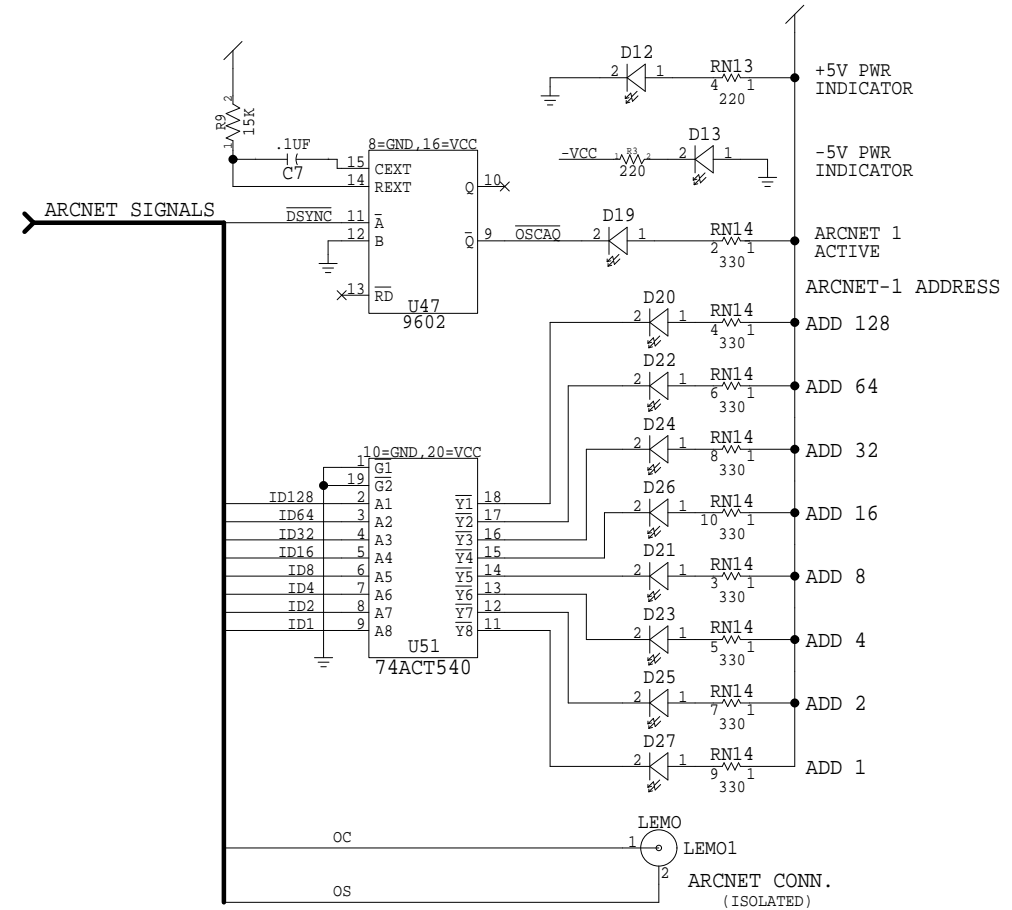
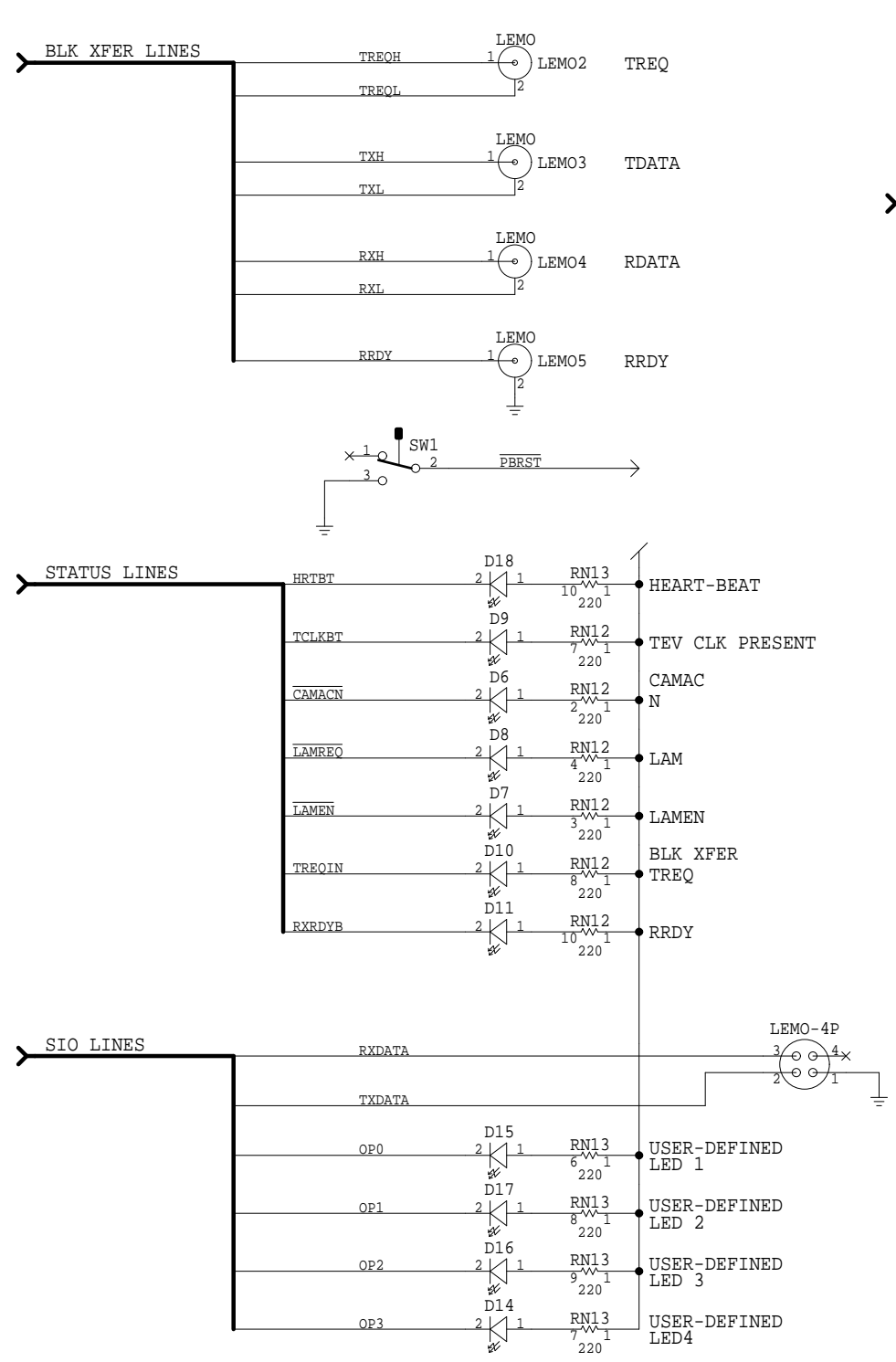

**C1045 FRONT PANEL**  
 (OP0-3)  
 (TXDATA)  
 (RXDATA)  
 PBRST  
 PWR  
 CAMACN  
 LAM  
 LAMEN  
 HRTBT  
 TCLK

SHEET 6

REF. 1045FPNL.SCH

DRAWN		DATE		<b>C1045 FRONT PANEL</b>		
R. FLOOD		8/20/88				
CHECKED		DATE		SIZE	DWG. NO.	REV.
R. FLOOD		9/25/89		C	0880-EC-172840	
ISSUED				SCALE	NONE	SHEET 6 OF 9

8 7 6 5 4 3 2 1

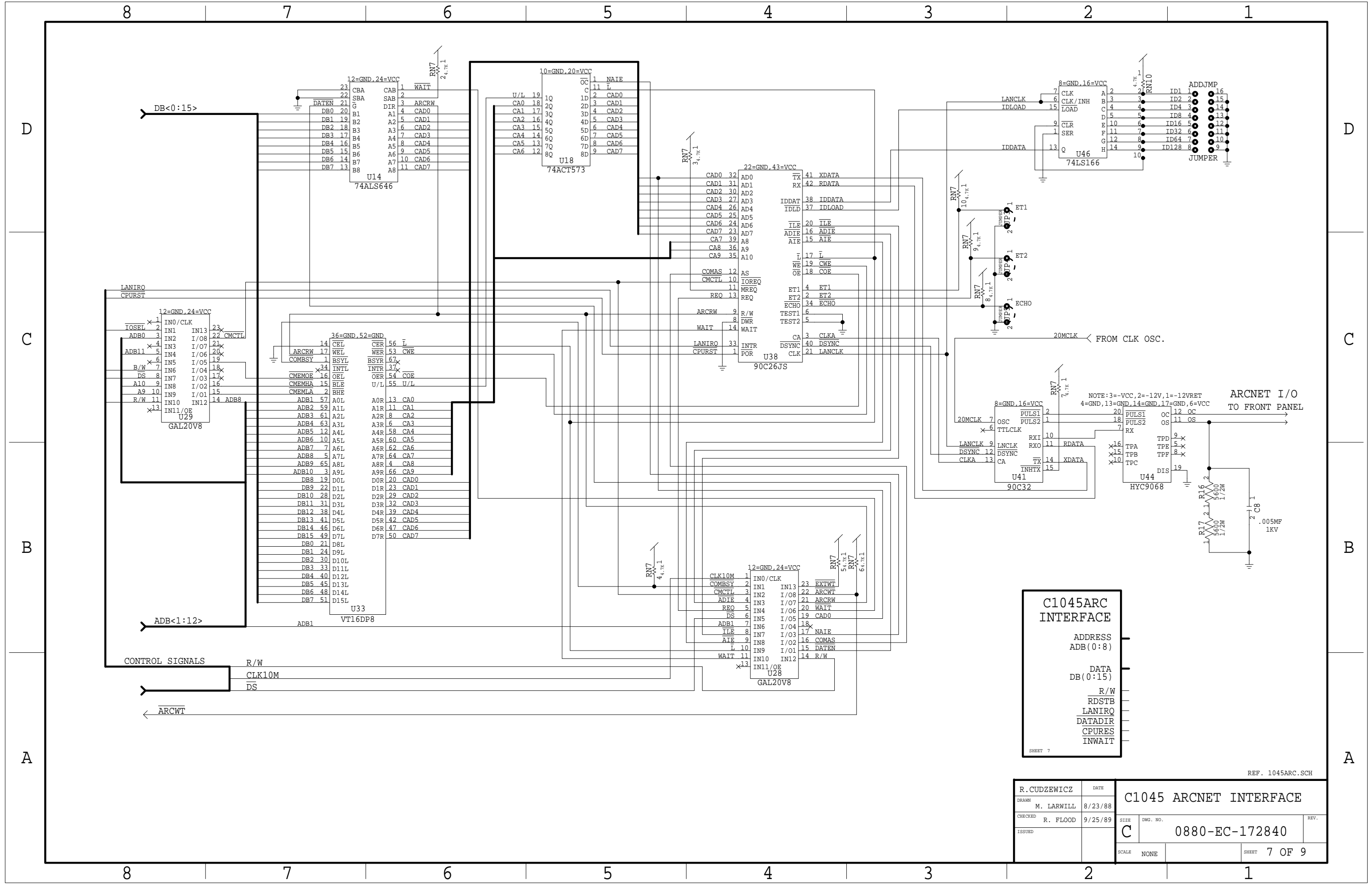

**C1045ARC  
INTERFACE**

ADDRESS  
ADB(0:8)

DATA  
DB(0:15)

R/W  
RDSTB  
LANIRQ  
DATADIR  
CPURES  
INWAIT

SHEET 7

REF. 1045ARC.SCH

R. CUDZEWICZ		DATE	C1045 ARCNET INTERFACE	
DRAWN	M. LARWILL	8/23/88	SIZE	DWG. NO.
CHECKED	R. FLOOD	9/25/89	C 0880-EC-172840	
ISSUED			SCALE	NONE
			SHEET 7 OF 9	

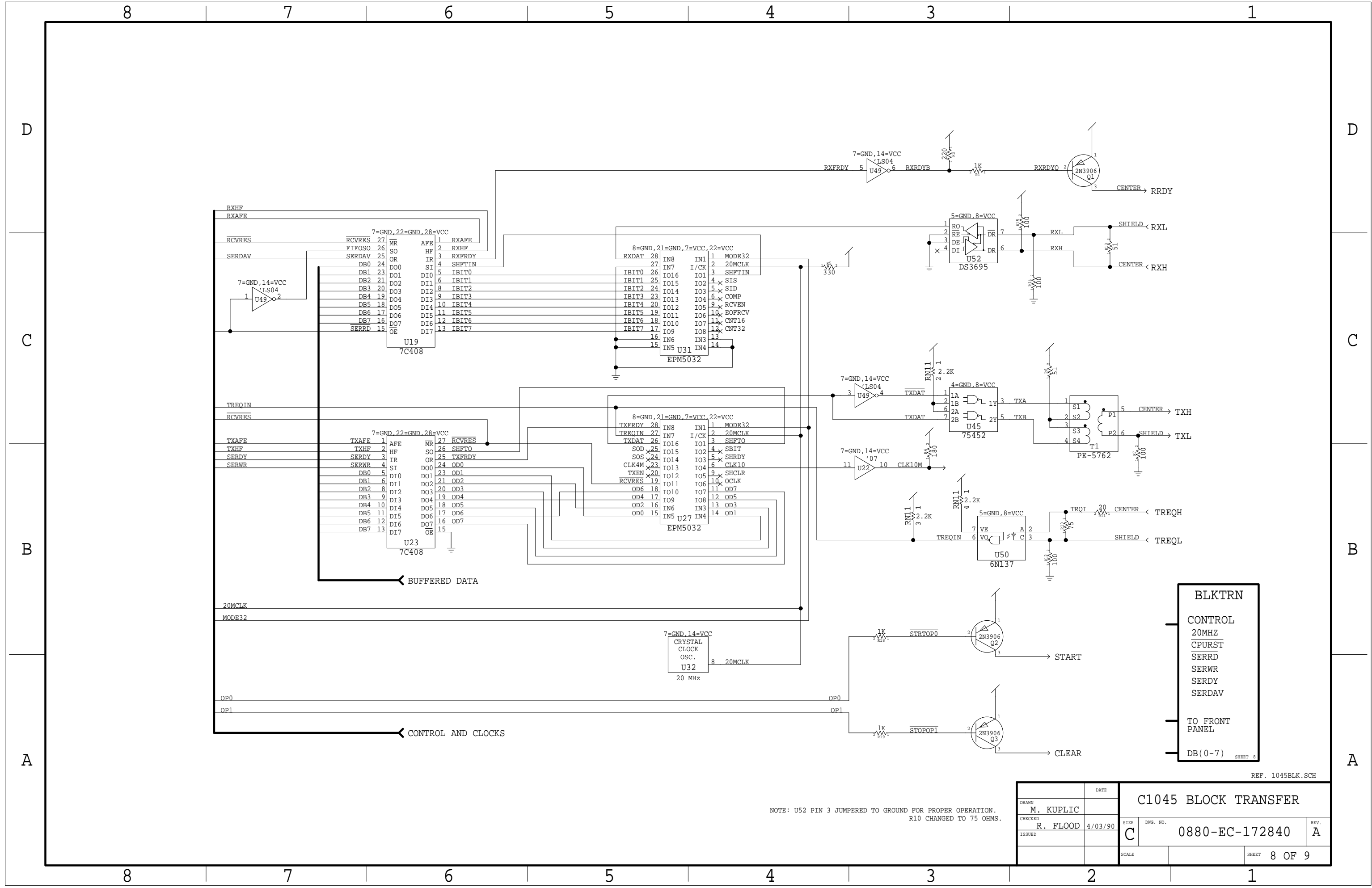

**BLKTRN**

CONTROL  
 20MHZ  
 CPURST  
 SERRD  
 SERWR  
 SERDY  
 SERDAV

TO FRONT PANEL

DB(0-7) SHEET 8

NOTE: U52 PIN 3 JUMPERED TO GROUND FOR PROPER OPERATION.  
 R10 CHANGED TO 75 OHMS.

DATE		C1045 BLOCK TRANSFER	
DRAWN M. KUPLIC	CHECKED R. FLOOD	SIZE C	DWG. NO. 0880-EC-172840
ISSUED		SCALE	REV. A
SHEET 8 OF 9			

REF. 1045BLK.SCH



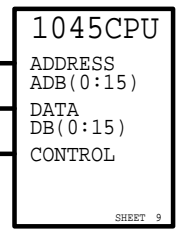
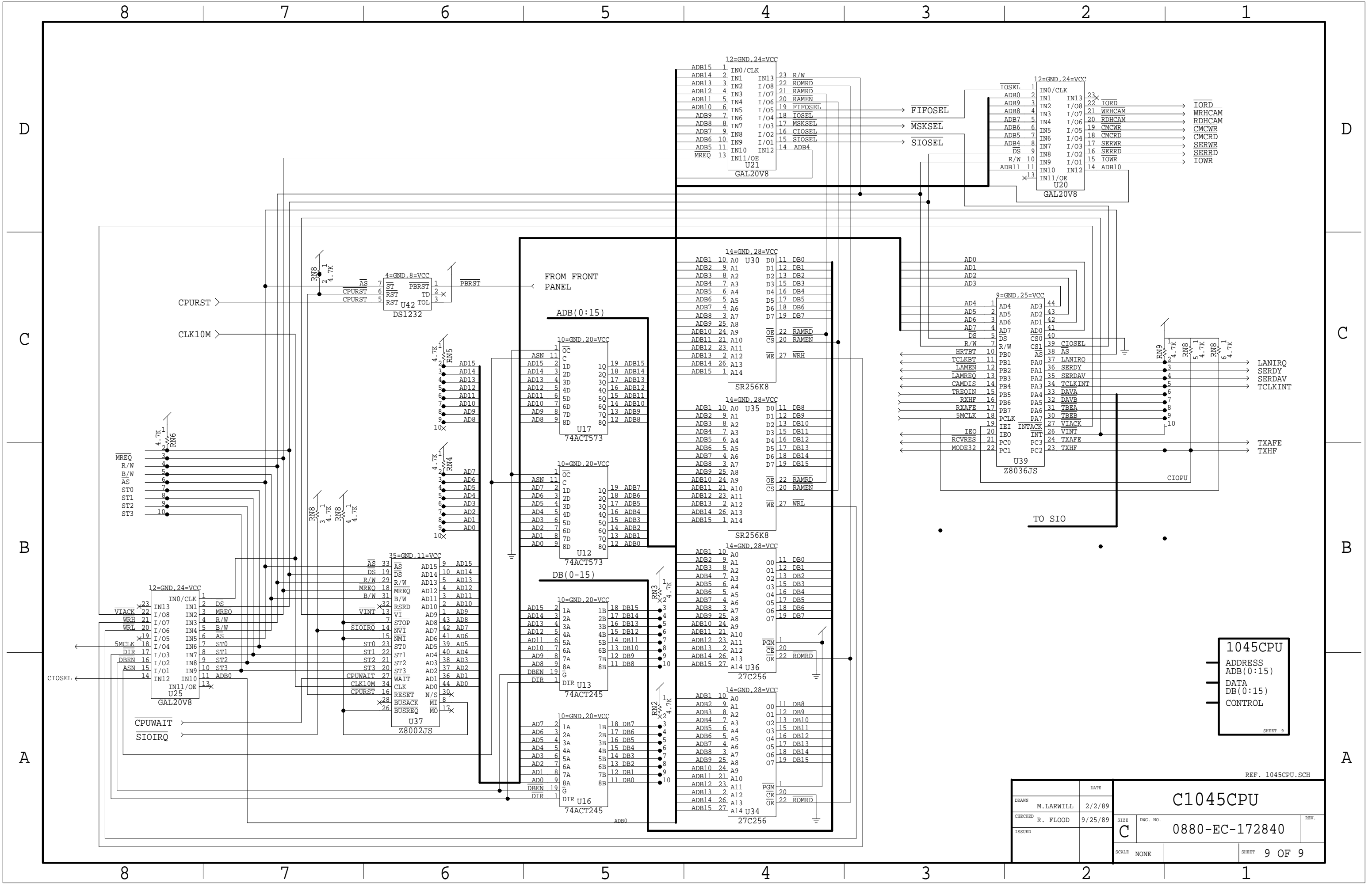

DRAWN		DATE		REV.	
M. LARWILL		2/2/89		C	
CHECKED		9/25/89		DWG. NO.	
ISSUED		C		0880-EC-172840	
SCALE		NONE		SHEET 9 OF 9	

REF. 1045CPU.SCH

C1045CPU